

ASME B16.20-2017
(Revision of ASME B16.20-2012)

Metallic Gaskets for Pipe Flanges

AN AMERICAN NATIONAL STANDARD



ASME B16.20-2017
(Revision of ASME B16.20-2012)

Metallic Gaskets for Pipe Flanges

Get more FREE standards from Standard Sharing Group and our chats

AN AMERICAN NATIONAL STANDARD



**The American Society of
Mechanical Engineers**

Two Park Avenue • New York, NY • 10016 USA

Date of Issuance: December 29, 2017

The next edition of this Standard is scheduled for publication in 2022.

ASME issues written replies to inquiries concerning interpretations of technical aspects of this Standard. Periodically certain actions of the ASME B16 Committee may be published as Cases. Cases and interpretations are published on the ASME Web site under the Committee Pages at <http://cstools.asme.org/> as they are issued.

Errata to codes and standards may be posted on the ASME Web site under the Committee Pages to provide corrections to incorrectly published items, or to correct typographical or grammatical errors in codes and standards. Such errata shall be used on the date posted.

The Committee Pages can be found at <http://cstools.asme.org/>. There is an option available to automatically receive an e-mail notification when errata are posted to a particular code or standard. This option can be found on the appropriate Committee Page after selecting "Errata" in the "Publication Information" section.

ASME is the registered trademark of The American Society of Mechanical Engineers.

This code or standard was developed under procedures accredited as meeting the criteria for American National Standards. The Standards Committee that approved the code or standard was balanced to assure that individuals from competent and concerned interests have had an opportunity to participate. The proposed code or standard was made available for public review and comment that provides an opportunity for additional public input from industry, academia, regulatory agencies, and the public-at-large.

ASME does not "approve," "rate," or "endorse" any item, construction, proprietary device, or activity.

ASME does not take any position with respect to the validity of any patent rights asserted in connection with any items mentioned in this document, and does not undertake to insure anyone utilizing a standard against liability for infringement of any applicable letters patent, nor assume any such liability. Users of a code or standard are expressly advised that determination of the validity of any such patent rights, and the risk of infringement of such rights, is entirely their own responsibility.

Participation by federal agency representative(s) or person(s) affiliated with industry is not to be interpreted as government or industry endorsement of this code or standard.

ASME accepts responsibility for only those interpretations of this document issued in accordance with the established ASME procedures and policies, which precludes the issuance of interpretations by individuals.

No part of this document may be reproduced in any form,
in an electronic retrieval system or otherwise,
without the prior written permission of the publisher.

The American Society of Mechanical Engineers
Two Park Avenue, New York, NY 10016-5990

Copyright © 2017 by
THE AMERICAN SOCIETY OF MECHANICAL ENGINEERS
All rights reserved
Printed in U.S.A.

CONTENTS

Foreword	v
Committee Roster	vi
Correspondence With the B16 Committee	vii
Important Information Concerning Use of Asbestos or Alternative Materials	ix
Summary of Changes	x
List of Changes in Record Number Order	xi
PART GR General Requirements	1
GR-1 Scope	1
GR-2 Quality Systems	1
GR-3 References	1
GR-4 Relevant Units	1
PART RJ Ring-Joint Gaskets	2
RJ-1 Types	2
RJ-2 Size	2
RJ-3 Materials	2
RJ-4 Marking	2
RJ-5 Dimensions and Tolerances	2
RJ-6 Surface Finish	2
RJ-7 Identification Number	2
PART SW Spiral-Wound Gaskets	15
SW-1 Size and Class	15
SW-2 Dimensions and Tolerances	15
SW-3 Materials	16
SW-4 Marking	16
PART JA Jacketed Gaskets	33
JA-1 Size and Pressure Class	33
JA-2 Design	33
JA-3 Dimensions and Tolerances	33
JA-4 Materials	33
JA-5 Marking	33
PART GM Grooved Metal Gaskets With Covering Layers	39
GM-1 Size and Class	39
GM-2 Dimensions and Tolerances	39
GM-3 Materials	39
GM-4 Marking	39
Mandatory Appendix	
I References	48

Nonmandatory Appendix

A	Quality System Program	49
---	----------------------------------	----

Figures

SW-2.1-1	Spiral-Wound Gasket	17
JA-3-1	Jacketed Gasket	34
GM-2.1-1	Grooved Metal Gasket With Covering Layers	40
GM-4.1-1	Illustration of Example Markings for Grooved Metal Gaskets With Covering Layers	47

Tables

RJ-3.2-1	Maximum Hardness for Ring Gaskets	3
RJ-4-1	Ring Gasket Markings	3
RJ-5-1	Type R Ring Gasket Dimensions and Tolerances	4
RJ-5-2	Pipe Sizes for Type R Ring Gaskets Suitable for Referenced Standards	7
RJ-5-3	Type RX Ring Gasket Dimensions and Tolerances	10
RJ-5-4	Pipe Sizes for Type RX Ring Gaskets Suitable for Referenced Standards	12
RJ-5-5	Type BX Ring Gasket Dimensions and Tolerances	13
RJ-5-6	Pipe Sizes for Type BX Ring Gaskets Suitable for Referenced Standards	14
SW-2.1-1	Dimensions for Spiral-Wound Gaskets Used With ASME B16.5 Flanges	18
SW-2.1-2	Dimensions for Spiral-Wound Gaskets Used With ASME B16.47 Series A Flanges	20
SW-2.1-3	Dimensions for Spiral-Wound Gaskets Used With ASME B16.47 Series B Flanges	22
SW-2.1-4	Inside Diameters of Inner Rings for Spiral-Wound Gaskets for Use With ASME B16.5 Flanges	24
SW-2.1-5	Inside Diameters of Inner Rings for Spiral-Wound Gaskets Used Between ASME B16.47 Series A Flanges	25
SW-2.1-6	Inside Diameters of Inner Rings for Spiral-Wound Gaskets Used Between ASME B16.47 Series B Flanges	26
SW-2.5-1	Minimum Pipe Wall Thickness Suitable for Use of Spiral-Wound Gaskets With Inner Rings for ASME B16.5 Flanges	27
SW-2.5-2	Maximum Bore of ASME B16.5 Flanges for Use With Spiral-Wound Gaskets	28
SW-2.5-3	Maximum Bore of ASME B16.47 Series A Flanges for Use With Spiral-Wound Gaskets	29
SW-2.5-4	Maximum Bore of ASME B16.47 Series B Flanges for Use With Spiral-Wound Gaskets	30
SW-3-1	Color Coding and Abbreviations for Spiral-Wound Gasket Materials	31
SW-4.1-1	Example Markings for Spiral-Wound Gaskets	32
JA-3-1	Jacketed Gasket Dimensions for ASME B16.5 Flanges	35
JA-3-2	Jacketed Gasket Dimensions for ASME B16.47 Series A Flanges	36
JA-3-3	Jacketed Gasket Dimensions for ASME B16.47 Series B Flanges	37
JA-4-1	Abbreviations for Identifying Materials for Jacketed Gaskets	38
JA-5.1-1	Example Markings for Jacketed Gaskets	38
GM-2.1-1	Dimensions for Grooved Metal Gaskets With Covering Layers Used With ASME B16.5 Flanges	41
GM-2.1-2	Dimensions for Grooved Metal Gaskets With Covering Layers Used With ASME B16.47 Series A Flanges	42
GM-2.1-3	Dimensions for Grooved Metal Gaskets With Covering Layers Used With ASME B16.47 Series B Flanges	44
GM-3.1-1	Color Coding and Abbreviations for Grooved Metal Gaskets With Covering Layers Materials	46
GM-4.1-1	Example Markings for Grooved Metal Gaskets With Covering Layers	47

FOREWORD

Ring-joint gaskets and grooves probably originated in the boiler field, where they were used in various forms for manhole covers, autoclaves, and other closures; however, it was in the oil industry (both in the production and refining of oil) that they received the greatest recognition and were developed into their present form. Their use expanded steadily as temperatures and pressures were increased in steam plants. Tests examining their application in flanges and valves were conducted as early as 1928.

In June 1936, the American Petroleum Institute (API) issued Tentative Standard 5-G-3 on Ring-Joints for Steel Flanges and Flange Unions for use with API Tubular Goods. This standard was known as API Specification 6B, Ring-Joint Flanges. Following the acceptance of ring-joints for flanges and valves by API and the issuance of their standard, ASA B16e on Steel Pipe Flanges and Flanged Fittings was revised to include them, and the 1939 edition included standard dimensions for a full line of ring-joint flanges based on the API standard. Development work continued, and API formulated Standard 6E, Specification for Wellhead Equipment, which included ring-joints not covered in ASA B16e-1939.

In 1949, the American Standards Association (ASA), Sectional Committee B16, Subcommittee 3, Steel Flanges and Flanged Fittings, assembled the available information on ring-joint gaskets into a single standard. ASA approved the Standard, with the designation ASA B16.20-1952, on April 30, 1952.

On April 4, 1955, ASA approved an updated edition with the designation ASA B16.20-1955. Ring gaskets for Class 900 (900 lb at that time) in sizes NPS 26 through NPS 36 were added in the next edition, which ASA approved on April 2, 1956. The Standard was again reviewed in 1962, and ASA approved it on April 25, 1963. In 1973, the Standard was revised, and the American National Standards Institute (ANSI) approved it as an American National Standard.

Following publication of the 1973 edition, API requested that ASME convert their gasket standard, API 601, into an ASME American National Standard. As a result of that request, the Standard was expanded to include requirements for spiral-wound and jacketed gaskets that were formerly listed in API 601, 7th edition, 1988. Ring-joint groove dimensions were not included, because they were included in ASME/ANSI B16.5-1988, Pipe Flanges and Flanged Fittings, and ASME B16.47-1990, Large Diameter Steel Flanges. The revised Standard was approved by ANSI on January 22, 1993.

Subsequent editions further expanded the Standard. In the 1998 edition, a quality system program annex was added. In the 2007 edition, metric dimensions were adopted as an independent standard to the U.S. Customary units, and Mandatory Appendix I was added to cover dimensional tables in U.S. Customary units. In the 2012 edition, a new chapter for grooved metal gaskets with covering layers was added.

In this 2017 edition, the entire Standard has been reorganized based on the different types of gaskets. In addition, the title of the Standard has been revised, as have multiple paragraphs, tables, and figures. Following approval by the ASME B16 Standards Committee, ANSI approved ASME B16.20-2017 as an American National Standard on October 11, 2017.

ASME B16 COMMITTEE

Standardization of Valves, Flanges, Fittings, and Gaskets

(The following is the roster of the Committee at the time of approval of this Standard.)

STANDARDS COMMITTEE OFFICERS

R. M. Bojarczuk, *Chair*
C. E. Davila, *Vice Chair*
C. R. Ramcharran, *Secretary*

STANDARDS COMMITTEE PERSONNEL

A. Appleton , Alloy Stainless Products Co., Inc.	R. C. Merrick , Fluor Enterprises
J. E. Barker , Dezurik Water Controls	M. L. Nayyar , NICE
K. Barron , Ward Manufacturing	W. H. Patrick , Dow Chemical Co.
D. C. Bayreuther , Metso Automation, Flow Control Division	D. Rahoji , CCM 2000
W. B. Bedesem , Consultant	C. R. Ramcharran , The American Society of Mechanical Engineers
R. M. Bojarczuk , ExxonMobil Research & Engineering Co.	D. F. Reid , VSP Technologies
A. M. Cheta , Qatar Shell GTL	R. A. Schmidt , Canadoil
M. A. Clark , NIBCO, Inc.	J. Tucker , Flowserve
G. A. Cuccio , Capitol Manufacturing Co.	F. R. Volgstadt , Volgstadt & Associates, Inc.
J. D'Avanzo , Fluoroseal Valves	F. Feng , <i>Delegate</i> , China Productivity Center for Machinery, National Technical Committee
C. E. Davila , Crane Energy	R. Barnes , <i>Contributing Member</i> , Anric Enterprises, Inc.
K. S. Felder , Valero Energy	P. V. Craig , <i>Contributing Member</i> , Jomar Group
D. R. Frikken , Becht Engineering Co.	B. G. Fabian , <i>Contributing Member</i> , Pennsylvania Machine Works
R. B. Hai , RBH Associates	M. Katcher , <i>Contributing Member</i> , Haynes International
D. Hunt, Jr. , Fastenal Co.	A. G. Kireta, Jr. , <i>Contributing Member</i> , Copper Development Association, Inc.
G. A. Jolly , Samshin, Ltd.	
E. J. Lain , Exelon Nuclear	
T. A. McMahon , Emerson Process Management	

SUBCOMMITTEE G — GASKETS FOR FLANGED JOINTS

D. F. Reid , <i>Chair</i> , VSP Technologies	E. Jamalyaria , Flexitallic Engineering
E. J. Lain , <i>Vice Chair</i> , Exelon Nuclear	Y. Li , Flexitallic L.P.
C. Ramcharran , <i>Secretary</i> , The American Society of Mechanical Engineers	L. Melvin , Leader Global Technologies, Inc.
J. Baulch , Teadit North America	R. T. Mueller , Consultant
R. M. Bojarczuk , ExxonMobil Research & Engineering Co.	D. Reeves , Sealing and Bolting Technologies, LLC
K. S. Felder , Valero Energy	M. Ruffin , Chevron
P. R. Francis , Thermoseal, Inc.	C. Yoder , Garlock Sealing Technologies
D. R. Frikken , Becht Engineering Co.	H. Azibert , <i>Contributing Member</i> , Camtrack, LLC
K. E. Guenther , Shell	D. H. Monroe , <i>Contributing Member</i> , Consultant

CORRESPONDENCE WITH THE B16 COMMITTEE

General. ASME Standards are developed and maintained with the intent to represent the consensus of concerned interests. As such, users of this Standard may interact with the Committee by requesting interpretations, proposing revisions or a case, and attending Committee meetings. Correspondence should be addressed to:

Secretary, B16 Standards Committee
The American Society of Mechanical Engineers
Two Park Avenue
New York, NY 10016-5990
<http://go.asme.org/Inquiry>

Proposing Revisions. Revisions are made periodically to the Standard to incorporate changes that appear necessary or desirable, as demonstrated by the experience gained from the application of the Standard. Approved revisions will be published periodically.

The Committee welcomes proposals for revisions to this Standard. Such proposals should be as specific as possible, citing the paragraph number(s), the proposed wording, and a detailed description of the reasons for the proposal, including any pertinent documentation.

Proposing a Case. Cases may be issued to provide alternative rules when justified, to permit early implementation of an approved revision when the need is urgent, or to provide rules not covered by existing provisions. Cases are effective immediately upon ASME approval and shall be posted on the ASME Committee Web page.

Requests for Cases shall provide a Statement of Need and Background Information. The request should identify the Standard and the paragraph, figure, or table number(s), and be written as a Question and Reply in the same format as existing Cases. Requests for Cases should also indicate the applicable edition(s) of the Standard to which the proposed Case applies.

Interpretations. Upon request, the B16 Standards Committee will render an interpretation of any requirement of the Standard. Interpretations can only be rendered in response to a written request sent to the Secretary of the B16 Standards Committee.

Requests for interpretation should preferably be submitted through the online Interpretation Submittal Form. The form is accessible at <http://go.asme.org/InterpretationRequest>. Upon submittal of the form, the Inquirer will receive an automatic e-mail confirming receipt.

If the Inquirer is unable to use the online form, he/she may e-mail the request to the Secretary of the B16 Standards Committee at SecretaryB16@asme.org, or mail it to the above address. The request for an interpretation should be clear and unambiguous. It is further recommended that the Inquirer submit his/her request in the following format:

Subject:	Cite the applicable paragraph number(s) and the topic of the inquiry in one or two words.
Edition:	Cite the applicable edition of the Standard for which the interpretation is being requested.
Question:	Phrase the question as a request for an interpretation of a specific requirement suitable for general understanding and use, not as a request for an approval of a proprietary design or situation. Please provide a condensed and precise question, composed in such a way that a "yes" or "no" reply is acceptable.
Proposed Reply(ies):	Provide a proposed reply(ies) in the form of "Yes" or "No," with explanation as needed. If entering replies to more than one question, please number the questions and replies.
Background Information:	Provide the Committee with any background information that will assist the Committee in understanding the inquiry. The Inquirer may also include any plans or drawings that are necessary to explain the question; however, they should not contain proprietary names or information.

Requests that are not in the format described above may be rewritten in the appropriate format by the Committee prior to being answered, which may inadvertently change the intent of the original request.

Moreover, ASME does not act as a consultant for specific engineering problems or for the general application or understanding of the Standard requirements. If, based on the inquiry information submitted, it is the opinion of the Committee that the Inquirer should seek assistance, the inquiry will be returned with the recommendation that such assistance be obtained.

ASME procedures provide for reconsideration of any interpretation when or if additional information that might affect an interpretation is available. Further, persons aggrieved by an interpretation may appeal to the cognizant ASME Committee or Subcommittee. ASME does not “approve,” “certify,” “rate,” or “endorse” any item, construction, proprietary device, or activity.

Attending Committee Meetings. The B16 Standards Committee regularly holds meetings and/or telephone conferences that are open to the public. Persons wishing to attend any meeting and/or telephone conference should contact the Secretary of the B16 Standards Committee.

IMPORTANT INFORMATION CONCERNING USE OF ASBESTOS OR ALTERNATIVE MATERIALS

Asbestos is referenced for use as a filler material in metallic gaskets. It has served as a universal sealing material, compatible with most fluid services. It has been of extreme usefulness in minimizing fire hazards.

Certain serious adverse health effects are associated with asbestos, among them the serious and often fatal diseases of lung cancer, asbestosis, and mesothelioma (a cancer of the chest and abdominal linings). The degree of exposure to asbestos varies with the product and the work practices involved.

Consult the most recent edition of the Occupational Safety and Health Administration, U.S. Department of Labor, Occupational Safety and Health Standard for Asbestos, Tremolite, Anthophyllite, and Actinolite, 29 Code of Federal Regulations Section 1910.1001; the U.S. Environmental Protection Agency National Emission Standard for Asbestos, 40 Code of Federal Regulations Sections 61.140 through 61.156; and the U.S. Environmental Protection Agency rule requiring the labeling and phased banning of asbestos products, published at 51 Federal Register 3738-3759 (January 29, 1986).

There are currently in use and under development a number of substitute materials to replace asbestos in certain applications. Manufacturers and users are encouraged to develop and use effective substitute materials that can meet the specifications for, and operating requirements of, the equipment to which they would apply.

Information concerning safety and health risks and proper precautions with respect to particular materials and conditions should be obtained from one's employer, the manufacturer or supplier of that material, or the Material Safety Data Sheet.

Get more **FREE** standards from [Standard Sharing Group](#) and our [chats](#)

ASME B16.20-2017

SUMMARY OF CHANGES

Following approval by the B16 Committee and ASME, and after public review, ASME B16.20-2017 was approved by the American National Standards Institute on October 11, 2017.

ASME B16.20-2017 has been revised in its entirety. The Standard title has been revised (13-901); the paragraphs, figures, and tables have been restructured and redesignated (14-756); and cross-references have been updated accordingly. In addition, this edition includes the following changes identified by a margin note, (17). The Record Numbers cited above and listed below are explained in more detail in “List of Changes in Record Number Order” following this Summary of Changes.

<i>Page</i>	<i>Location</i>	<i>Change (Record Number)</i>
15	SW-2.2	Formerly para. 3.2.2; revised (16-2540)
16	SW-2.6	Formerly para. 3.2.6; revised (12-519, 16-2540)
17	Figure SW-2.1-1	Formerly Figures 1 and I-1; revised (14-750)
18	Table SW-2.1-1	Formerly Tables 9 and I-4; values for NPS 3½ added and Notes revised (16-2147)
20	Table SW-2.1-2	Formerly Tables 10 and I-5; General Notes and Note (2) revised (13-914)
22	Table SW-2.1-3	Formerly Tables 11 and I-6; under “U.S. Customary, in.,” Inside Diameter of Gasket for NPS 38 and NPS 58, and Outside Diameter of Gasket for NPS 56 revised; and Note (2) revised (13-914)
24	Table SW-2.1-4	Formerly Tables 12 and I-7; values for NPS 3½ added and Note (1) revised (16-2147)
40	Figure GM-2.1-1	Formerly Figure 3; revised (14-758)

LIST OF CHANGES IN RECORD NUMBER ORDER

<u>Record Number</u>	<u>Change</u>
12-519	Deleted para. 3.2.6.
13-901	Revised title of the Standard.
13-914	Editorially revised Tables I-5 and I-6.
14-750	In Figures 1 and I-1, provided guidance into the measurement of the outside diameter of gaskets.
14-756	Reorganized ASME B16.20 based on the different gasket types.
14-758	Clarified groove details in Figure 3.
16-2147	Added data for NPS 3½ flange to Tables 9, 12, I-4, and I-7.
16-2540	Revised existing para. 3.2.2 and added para. 3.2.6 to replace the now-deleted para. 3.2.6. The revised construction and compression criteria will permit filler to extend above the metal winding and have adequate compressive strength to resist expected bolt loads for a given flange Class, and reflects current bolting practices per ASME PCC-1 where bolt stress is based on gasket stress.

Get more FREE standards from Standard Sharing Group and our chats

INTENTIONALLY LEFT BLANK

PART GR

GENERAL REQUIREMENTS

GR-1 SCOPE

This Standard covers materials, dimensions, tolerances, and markings for metal ring-joint gaskets, spiral-wound metal gaskets, metal-jacketed gaskets, and grooved metal gaskets with covering layers. These gaskets are dimensionally suitable for use with flanges described in reference flange standards ASME B16.5, ASME B16.47, API Specification 6A, and ISO 10423.

GR-2 QUALITY SYSTEMS

Requirements relating to the product manufacturers' quality system programs are described in [Nonmandatory Appendix A](#).

GR-3 REFERENCES

Standards and specifications adopted by reference in this Standard are shown in [Mandatory Appendix I](#).

GR-4 RELEVANT UNITS

This Standard states values in both SI (Metric) and U.S. Customary units. These systems of units are to be regarded separately as standard. Within the text, the U.S. Customary units are shown in parentheses. The values stated in each system are not exact equivalents; therefore, it is required that each system of units be used independently of the other. Combining values from the two systems constitutes nonconformance with the Standard.

Get more FREE standards from Standard Sharing Group and our chats

PART RJ

RING-JOINT GASKETS

RJ-1 TYPES

Ring-joint gaskets shall be either octagonal or oval in cross section.

RJ-2 SIZE

Ring-joint gaskets shall be identified by an R, RX, or BX number that relates to flange size (NPS), pressure class, and the appropriate flange standards (ASME B16.5, ASME B16.47, API Specification 6A, or ISO 10423).

RJ-3 MATERIALS

RJ-3.1 General

Ring-joint gasket materials, some of which are listed in [Table RJ-3.2-1](#), shall be selected by the user based on suitability for the service conditions.

It is recommended that ring-joint gaskets be of a lesser hardness than that of the mating flanges.

RJ-3.2 Hardness

Ring-joint gaskets of materials listed in [Table RJ-3.2-1](#) shall have a hardness equal to or less than that shown in [Table RJ-3.2-1](#).

RJ-4 MARKING

The outer surface of each gasket shall carry the manufacturer's name or identification trademark and gasket number prefixed by the letters R, RX, or BX, followed by the gasket material identification. Materials shall be identified as shown in [Table RJ-4-1](#). The gasket shall also be marked with an ASME B16.20 designation. The marking shall be applied so as not to harmfully distort the gasket or affect the integrity of the seal.

RJ-5 DIMENSIONS AND TOLERANCES

Dimensions and tolerances for ring-joint gaskets shall be as shown in [Tables RJ-5-1](#) through [RJ-5-6](#).

RJ-6 SURFACE FINISH

Types R and RX gaskets shall have a surface finish not rougher than 1.6 μm (63 $\mu\text{in.}$) roughness. Type BX gaskets shall have a surface finish not rougher than 0.8 μm (32 $\mu\text{in.}$) roughness. Surface finish shall pertain to the gasket-sealing surface.

RJ-7 IDENTIFICATION NUMBER

Dimensional reference identification numbers are assigned to ring-joint gaskets and shown in [Tables RJ-5-1](#) through [RJ-5-6](#).

Table RJ-3.2-1 Maximum Hardness for Ring Gaskets

Ring Gasket Material	Maximum Hardness	
	Brinell	Rockwell "B" Scale
Soft iron [Note (1)]	90	56
Low-carbon steel	120	68
4-6 chrome $\frac{1}{2}$ Mo	130	72
Type 410	170	86
Type 304	160	83
Type 316	160	83
Type 347	160	83

NOTE: (1) May be low-carbon steel, not to exceed maximum hardness of 90 Brinell — 56 Rockwell "B."

Table RJ-4-1 Ring Gasket Markings

Ring Gasket Material	Identification	Marking Example [Note (1)]
Soft iron [Note (2)]	D	R51D
Low-carbon steel	S	R51S
4-6 chrome $\frac{1}{2}$ Mo	F5 [Note (3)]	R51F5
Type 410	S 410	R51S410
Type 304	S 304	R51S304
Type 316	S 316	R51S316
Type 347	S 347	R51S347

NOTES:

- (1) This number shall be preceded by the manufacturer's name or identification trademark.
- (2) May be low-carbon steel, not to exceed maximum hardness of 90 Brinell — 56 Rockwell "B."
- (3) F5 identification designates ASTM specification A182-72 chemical composition requirements only.

Table RJ-5-1 Type R Ring Gasket Dimensions and Tolerances

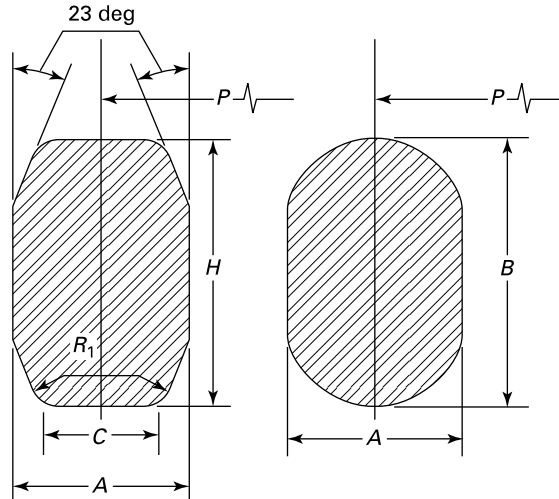

Ring Number	Average Pitch Diameter of Ring, P, mm (in.)	Width of Ring, A, mm (in.)	Height of Ring, mm (in.)		Width of Flat on Octagonal Ring, C, mm (in.)	Radius in Octagonal Ring, R ₁ , mm (in.)
			Oval, B	Octagonal, H		
R-11	34.14 (1.344)	6.35 (0.250)	11.2 (0.44)	9.7 (0.38)	4.32 (0.170)	1.5 (0.06)
R-12	39.70 (1.563)	7.95 (0.313)	14.2 (0.56)	12.7 (0.50)	5.23 (0.206)	1.5 (0.06)
R-13	42.88 (1.688)	7.95 (0.313)	14.2 (0.56)	12.7 (0.50)	5.23 (0.206)	1.5 (0.06)
R-14	44.45 (1.750)	7.95 (0.313)	14.2 (0.56)	12.7 (0.50)	5.23 (0.206)	1.5 (0.06)
R-15	47.63 (1.875)	7.95 (0.313)	14.2 (0.56)	12.7 (0.50)	5.23 (0.206)	1.5 (0.06)
R-16	50.80 (2.000)	7.95 (0.313)	14.2 (0.56)	12.7 (0.50)	5.23 (0.206)	1.5 (0.06)
R-17	57.15 (2.250)	7.95 (0.313)	14.2 (0.56)	12.7 (0.50)	5.23 (0.206)	1.5 (0.06)
R-18	60.33 (2.375)	7.95 (0.313)	14.2 (0.56)	12.7 (0.50)	5.23 (0.206)	1.5 (0.06)
R-19	65.10 (2.563)	7.95 (0.313)	14.2 (0.56)	12.7 (0.50)	5.23 (0.206)	1.5 (0.06)
R-20	68.28 (2.688)	7.95 (0.313)	14.2 (0.56)	12.7 (0.50)	5.23 (0.206)	1.5 (0.06)
R-21	72.24 (2.844)	11.13 (0.438)	17.5 (0.69)	16.0 (0.63)	7.75 (0.305)	1.5 (0.06)
R-22	82.55 (3.250)	7.95 (0.313)	14.2 (0.56)	12.7 (0.50)	5.23 (0.206)	1.5 (0.06)
R-23	82.55 (3.250)	11.13 (0.438)	17.5 (0.69)	16.0 (0.63)	7.75 (0.305)	1.5 (0.06)
R-24	95.25 (3.750)	11.13 (0.438)	17.5 (0.69)	16.0 (0.63)	7.75 (0.305)	1.5 (0.06)
R-25	101.60 (4.000)	7.95 (0.313)	14.2 (0.56)	12.7 (0.50)	5.23 (0.206)	1.5 (0.06)
R-26	101.60 (4.000)	11.13 (0.438)	17.5 (0.69)	16.0 (0.63)	7.75 (0.305)	1.5 (0.06)
R-27	107.95 (4.250)	11.13 (0.438)	17.5 (0.69)	16.0 (0.63)	7.75 (0.305)	1.5 (0.06)
R-28	111.13 (4.375)	12.70 (0.500)	19.1 (0.75)	17.5 (0.69)	8.66 (0.341)	1.5 (0.06)
R-29	114.30 (4.500)	7.95 (0.313)	14.2 (0.56)	12.7 (0.50)	5.23 (0.206)	1.5 (0.06)
R-30	117.48 (4.625)	11.13 (0.438)	17.5 (0.69)	16.0 (0.63)	7.75 (0.305)	1.5 (0.06)
R-31	123.83 (4.875)	11.13 (0.438)	17.5 (0.69)	16.0 (0.63)	7.75 (0.305)	1.5 (0.06)
R-32	127.00 (5.000)	12.70 (0.500)	19.1 (0.75)	17.5 (0.69)	8.66 (0.341)	1.5 (0.06)
R-33	131.78 (5.188)	7.95 (0.313)	14.2 (0.56)	12.7 (0.50)	5.23 (0.206)	1.5 (0.06)
R-34	131.78 (5.188)	11.13 (0.438)	17.5 (0.69)	16.0 (0.63)	7.75 (0.305)	1.5 (0.06)
R-35	136.53 (5.375)	11.13 (0.438)	17.5 (0.69)	16.0 (0.63)	7.75 (0.305)	1.5 (0.06)
R-36	149.23 (5.875)	7.95 (0.313)	14.2 (0.56)	12.7 (0.50)	5.23 (0.206)	1.5 (0.06)
R-37	149.23 (5.875)	11.13 (0.438)	17.5 (0.69)	16.0 (0.63)	7.75 (0.305)	1.5 (0.06)
R-38	157.18 (6.188)	15.88 (0.625)	22.4 (0.88)	20.6 (0.81)	10.49 (0.413)	1.5 (0.06)
R-39	161.93 (6.375)	11.13 (0.438)	17.5 (0.69)	16.0 (0.63)	7.75 (0.305)	1.5 (0.06)

Table RJ-5-1 Type R Ring Gasket Dimensions and Tolerances (Cont'd)

Ring Number	Average Pitch Diameter of Ring, <i>P</i> , mm (in.)	Width of Ring, <i>A</i> , mm (in.)	Height of Ring, mm (in.)		Width of Flat on Octagonal Ring, <i>C</i> , mm (in.)	Radius in Octagonal Ring, <i>R</i> ₁ , mm (in.)
			Oval, <i>B</i>	Octagonal, <i>H</i>		
R-40	171.45 (6.750)	7.95 (0.313)	14.2 (0.56)	12.7 (0.50)	5.23 (0.206)	1.5 (0.06)
R-41	180.98 (7.125)	11.13 (0.438)	17.5 (0.69)	16.0 (0.63)	7.75 (0.305)	1.5 (0.06)
R-42	190.50 (7.500)	19.05 (0.750)	25.4 (1.00)	23.9 (0.94)	12.32 (0.485)	1.5 (0.06)
R-43	193.68 (7.625)	7.95 (0.313)	14.2 (0.56)	12.7 (0.50)	5.23 (0.206)	1.5 (0.06)
R-44	193.68 (7.625)	11.13 (0.438)	17.5 (0.69)	16.0 (0.63)	7.75 (0.305)	1.5 (0.06)
R-45	211.15 (8.313)	11.13 (0.438)	17.5 (0.69)	16.0 (0.63)	7.75 (0.305)	1.5 (0.06)
R-46	211.15 (8.313)	12.70 (0.500)	19.1 (0.75)	17.5 (0.69)	8.66 (0.341)	1.5 (0.06)
R-47	228.60 (9.000)	19.05 (0.750)	25.4 (1.00)	23.9 (0.94)	12.32 (0.485)	1.5 (0.06)
R-48	247.65 (9.750)	7.95 (0.313)	14.2 (0.56)	12.7 (0.50)	5.23 (0.206)	1.5 (0.06)
R-49	269.88 (10.625)	11.13 (0.438)	17.5 (0.69)	16.0 (0.63)	7.75 (0.305)	1.5 (0.06)
R-50	269.88 (10.625)	15.88 (0.625)	22.4 (0.88)	20.6 (0.81)	10.49 (0.413)	1.5 (0.06)
R-51	279.40 (11.000)	22.23 (0.875)	28.7 (1.13)	26.9 (1.06)	14.81 (0.583)	1.5 (0.06)
R-52	304.80 (12.000)	7.95 (0.313)	14.2 (0.56)	12.7 (0.50)	5.23 (0.206)	1.5 (0.06)
R-53	323.85 (12.750)	11.13 (0.438)	17.5 (0.69)	16.0 (0.63)	7.75 (0.305)	1.5 (0.06)
R-54	323.85 (12.750)	15.88 (0.625)	22.4 (0.88)	20.6 (0.81)	10.49 (0.413)	1.5 (0.06)
R-55	342.90 (13.500)	28.58 (1.125)	36.6 (1.44)	35.1 (1.38)	19.81 (0.780)	2.3 (0.09)
R-56	381.00 (15.000)	7.95 (0.313)	14.2 (0.56)	12.7 (0.50)	5.23 (0.206)	1.5 (0.06)
R-57	381.00 (15.000)	11.13 (0.438)	17.5 (0.69)	16.0 (0.63)	7.75 (0.305)	1.5 (0.06)
R-58	381.00 (15.000)	22.23 (0.875)	28.7 (1.13)	26.9 (1.06)	14.81 (0.583)	1.5 (0.06)
R-59	396.88 (15.625)	7.95 (0.313)	14.2 (0.56)	12.7 (0.50)	5.23 (0.206)	1.5 (0.06)
R-60	406.40 (16.000)	31.75 (1.250)	39.6 (1.56)	38.1 (1.50)	22.33 (0.879)	2.3 (0.09)
R-61	419.10 (16.500)	11.13 (0.438)	17.5 (0.69)	16.0 (0.63)	7.75 (0.305)	1.5 (0.06)
R-62	419.10 (16.500)	15.88 (0.625)	22.4 (0.88)	20.6 (0.81)	10.49 (0.413)	1.5 (0.06)
R-63	419.10 (16.500)	25.40 (1.000)	33.3 (1.31)	31.8 (1.25)	17.30 (0.681)	2.3 (0.09)
R-64	454.03 (17.875)	7.95 (0.313)	14.2 (0.56)	12.7 (0.50)	5.23 (0.206)	1.5 (0.06)
R-65	469.90 (18.500)	11.13 (0.438)	17.5 (0.69)	16.0 (0.63)	7.75 (0.305)	1.5 (0.06)
R-66	469.90 (18.500)	15.88 (0.625)	22.4 (0.88)	20.6 (0.81)	10.49 (0.413)	1.5 (0.06)
R-67	469.90 (18.500)	28.58 (1.125)	36.6 (1.44)	35.1 (1.38)	19.81 (0.780)	2.3 (0.09)
R-68	517.53 (20.375)	7.95 (0.313)	14.2 (0.56)	12.7 (0.50)	5.23 (0.206)	1.5 (0.06)
R-69	533.40 (21.000)	11.13 (0.438)	17.5 (0.69)	16.0 (0.63)	7.75 (0.305)	1.5 (0.06)
R-70	533.40 (21.000)	19.05 (0.750)	25.4 (1.00)	23.9 (0.94)	12.32 (0.485)	1.5 (0.06)
R-71	533.40 (21.000)	28.58 (1.125)	36.6 (1.44)	35.1 (1.38)	19.81 (0.780)	2.3 (0.09)
R-72	558.80 (22.000)	7.95 (0.313)	14.2 (0.56)	12.7 (0.50)	5.23 (0.206)	1.5 (0.06)
R-73	584.20 (23.000)	12.70 (0.500)	19.1 (0.75)	17.5 (0.69)	8.66 (0.341)	1.5 (0.06)
R-74	584.20 (23.000)	19.05 (0.750)	25.4 (1.00)	23.9 (0.94)	12.32 (0.485)	1.5 (0.06)
R-75	584.20 (23.000)	31.75 (1.250)	39.6 (1.56)	38.1 (1.50)	22.33 (0.879)	2.3 (0.09)
R-76	673.10 (26.500)	7.95 (0.313)	14.2 (0.56)	12.7 (0.50)	5.23 (0.206)	1.5 (0.06)
R-77	692.15 (27.250)	15.88 (0.625)	22.4 (0.88)	20.6 (0.81)	10.49 (0.413)	1.5 (0.06)
R-78	692.15 (27.250)	25.40 (1.000)	33.3 (1.31)	31.8 (1.25)	17.30 (0.681)	2.3 (0.09)
R-79	692.15 (27.250)	34.93 (1.375)	44.5 (1.75)	41.4 (1.63)	24.82 (0.977)	2.3 (0.09)
R-80	615.95 (24.250)	7.95 (0.313)	...	12.7 (0.50)	5.23 (0.206)	1.5 (0.06)

Table RJ-5-1 Type R Ring Gasket Dimensions and Tolerances (Cont'd)

Ring Number	Average Pitch Diameter of Ring, <i>P</i> , mm (in.)	Width of Ring, <i>A</i> , mm (in.)	Height of Ring, mm (in.)		Width of Flat on Octagonal Ring, <i>C</i> , mm (in.)	Radius in Octagonal Ring, <i>R</i> ₁ , mm (in.)
			Oval, <i>B</i>	Octagonal, <i>H</i>		
R-81	635.00 (25.000)	14.30 (0.563)	...	19.1 (0.75)	9.58 (0.377)	1.5 (0.06)
R-82	57.15 (2.250)	11.13 (0.438)	...	16.0 (0.63)	7.75 (0.305)	1.5 (0.06)
R-84	63.50 (2.500)	11.13 (0.438)	...	16.0 (0.63)	7.75 (0.305)	1.5 (0.06)
R-85	79.38 (3.125)	12.70 (0.500)	...	17.5 (0.69)	8.66 (0.341)	1.5 (0.06)
R-86	90.50 (3.563)	15.88 (0.625)	...	20.6 (0.81)	10.49 (0.413)	1.5 (0.06)
R-87	100.03 (3.938)	15.88 (0.625)	...	20.6 (0.81)	10.49 (0.413)	1.5 (0.06)
R-88	123.83 (4.875)	19.05 (0.750)	...	23.9 (0.94)	12.32 (0.485)	1.5 (0.06)
R-89	114.30 (4.500)	19.05 (0.750)	...	23.9 (0.94)	12.32 (0.485)	1.5 (0.06)
R-90	155.58 (6.125)	22.23 (0.875)	...	26.9 (1.06)	14.81 (0.583)	1.5 (0.06)
R-91	260.35 (10.250)	31.75 (1.250)	...	38.1 (1.50)	22.33 (0.879)	2.3 (0.09)
R-92	228.60 (9.000)	11.13 (0.438)	17.5 (0.69)	16.0 (0.63)	7.75 (0.305)	1.5 (0.06)
R-93	749.30 (29.500)	19.05 (0.750)	...	23.9 (0.94)	12.32 (0.485)	1.5 (0.06)
R-94	800.10 (31.500)	19.05 (0.750)	...	23.9 (0.94)	12.32 (0.485)	1.5 (0.06)
R-95	857.25 (33.750)	19.05 (0.750)	...	23.9(0.94)	12.32 (0.485)	1.5 (0.06)
R-96	914.40 (36.000)	22.23 (0.875)	...	26.9 (1.06)	14.81 (0.583)	1.5 (0.06)
R-97	965.20 (38.000)	22.23 (0.875)	...	26.9 (1.06)	14.81 (0.583)	1.5 (0.06)
R-98	1 022.35 (40.250)	22.23 (0.875)	...	26.9 (1.06)	14.81 (0.583)	1.5 (0.06)
R-99	234.95 (9.250)	11.13 (0.438)	...	16.0 (0.63)	7.75 (0.305)	1.5 (0.06)
R-100	749.30 (29.500)	28.58 (1.125)	...	35.1 (1.38)	19.81 (0.780)	2.3 (0.09)
R-101	800.10 (31.500)	31.75 (1.250)	...	38.1 (1.50)	22.33 (0.879)	2.3 (0.09)
R-102	857.25 (33.750)	31.75 (1.250)	...	38.1 (1.50)	22.33 (0.879)	2.3 (0.09)
R-103	914.40 (36.000)	31.75 (1.250)	...	38.1 (1.50)	22.33 (0.879)	2.3 (0.09)
R-104	965.20 (38.000)	34.93 (1.375)	...	41.4 (1.63)	24.82 (0.977)	2.3 (0.09)
R-105	1 022.35 (40.250)	34.93 (1.375)	...	41.4 (1.63)	24.82 (0.977)	2.3 (0.09)

GENERAL NOTE: Tolerances:

23 deg = angle, ± 0 deg 30 min ($\pm 1/2$ deg)*A* = width of ring, ± 0.20 mm (± 0.008 in.)*B*, *H* = height of ring, +1.3 mm, -0.5 mm (+0.05 in., -0.02 in.)

Variation in height throughout the entire circumference of any given ring shall not exceed 0.5 mm (0.02 in.) within these tolerances.

C = width of flat on octagonal ring, ± 0.20 mm (± 0.008 in.)*P* = average pitch diameter of ring, ± 0.18 mm (± 0.007 in.)*R*₁ = radius in ring, ± 0.5 mm (± 0.02 in.)

Table RJ-5-2 Pipe Sizes for Type R Ring Gaskets Suitable for Referenced Standards

Ring Number	Pressure Classes											
	ASME B16.5					API 6B				ASME B16.47 Series A		
	150	300-600	900	1500	2500	720-960 [Note (1)]	2000	3000	5000	150	300-600	900
R-11	...	1/2
R-12	1/2	1/2
R-13	...	3/4	1/2
R-14	3/4	3/4
R-15	1
R-16	...	1	1	1	3/4	1	1	1	1
R-17	1 1/4
R-18	...	1 1/4	1 1/4	1 1/4	1	1 1/4	1 1/4	1 1/4	1 1/4
R-19	1 1/2
R-20	...	1 1/2	1 1/2	1 1/2	...	1 1/2	1 1/2	1 1/2	1 1/2
R-21	1 1/4
R-22	2
R-23	...	2	1 1/2	2	2
R-24	2	2	2	2
R-25	2 1/2
R-26	...	2 1/2	2	2 1/2	2 1/2
R-27	2 1/2	2 1/2	2 1/2	2 1/2
R-28	2 1/2
R-29	3
R-30 [Note (2)]	...	3
R-31	...	3	3	3	3	3
R-32	3
R-33	3 1/2
R-34	...	3 1/2
R-35	3	3
R-36	4
R-37	...	4	4	4	4	4	3 1/2
R-38	4
R-39	4	4
R-40	5
R-41	...	5	5	5	5	5
R-42	5
R-43	6
R-44	5	5
R-45	...	6	6	6	6	6
R-46	6	6
R-47	6
R-48	8
R-49	...	8	8	8	8	8
R-50	8	8

Get more FREE standards from Standard Sharing Group and our chats

Table RJ-5-2 Pipe Sizes for Type R Ring Gaskets Suitable for Referenced Standards (Cont'd)

Ring Number	Pressure Classes											
	ASME B16.5					API 6B				ASME B16.47 Series A		
	150	300-600	900	1500	2500	720-960 [Note (1)]	2000	3000	5000	150	300-600	900
R-51	8
R-52	10
R-53	...	10	10	10	10	10
R-54	10	10
R-55	10
R-56	12
R-57	...	12	12	12	12	12
R-58	12
R-59	14
R-60	12
R-61	...	14	14	14	14
R-62	14
R-63	14
R-64	16
R-65	...	16	16	16
R-66	16	16
R-67	16
R-68	18
R-69	...	18	18	18
R-70	18	18
R-71	18
R-72	20
R-73	...	20	20	20
R-74	20	20
R-75	20
R-76	24
R-77	...	24
R-78	24
R-79	24
R-80
R-81
R-82	1
R-84	1½
R-85	2
R-86	2½
R-87	3
R-88	4
R-89	3½

Table RJ-5-2 Pipe Sizes for Type R Ring Gaskets Suitable for Referenced Standards (Cont'd)

Ring Number	Pressure Classes											
	ASME B16.5					API 6B				ASME B16.47 Series A		
	150	300-600	900	1500	2500	720-960 [Note (1)]	2000	3000	5000	150	300-600	900
R-90	5
R-91	10
R-92
R-93	26	...
R-94	28	...
R-95	30	...
R-96	32	...
R-97	34	...
R-98	36	...
R-99	8	8
R-100	26
R-101	28
R-102	30
R-103	32
R-104	34
R-105	36

GENERAL NOTE: End flanges to API 6D and API 600 use gaskets for equivalent pipe size under ASME B16.5 or ASME B16.47 Series A.

NOTES:

- (1) Class 720, 960, and 10000 flanges to API 6B are obsolete. Data are for information only.
- (2) R-30 is for lapped joint only.

Table RJ-5-3 Type RX Ring Gasket Dimensions and Tolerances

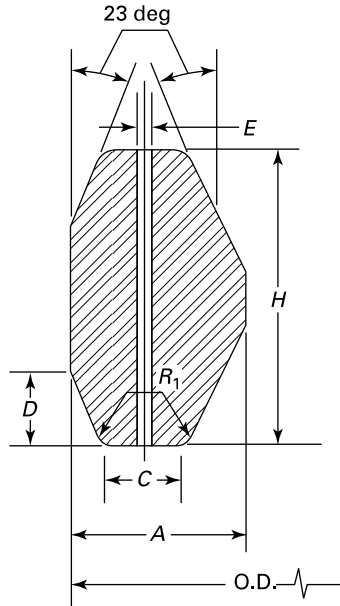

Ring Number	Outside Diameter of Ring, O.D., mm (in.)	Width of Ring, A, mm (in.)	Width of Flat, C, mm (in.)	Height of Outside Bevel, D, mm (in.)	Height of Ring, H, mm (in.)	Radius in Octagonal Ring, R ₁ , mm (in.)	Hole Size, E, mm (in.) [Note (1)]
RX-20	76.20 (3.000)	8.74 (0.344)	4.62 (0.182)	3.18 (0.125)	19.05 (0.750)	1.5 (0.06)	...
RX-23	93.27 (3.672)	11.91 (0.469)	6.45 (0.254)	4.24 (0.167)	25.40 (1.000)	1.5 (0.06)	...
RX-24	105.97 (4.172)	11.91 (0.469)	6.45 (0.254)	4.24 (0.167)	25.40 (1.000)	1.5 (0.06)	...
RX-25	109.55 (4.313)	8.74 (0.344)	4.62 (0.182)	3.18 (0.125)	19.05 (0.750)	1.5 (0.06)	...
RX-26	111.91 (4.406)	11.91 (0.469)	6.45 (0.254)	4.24 (0.167)	25.40 (1.000)	1.5 (0.06)	...
RX-27	118.26 (4.656)	11.91 (0.469)	6.45 (0.254)	4.24 (0.167)	25.40 (1.000)	1.5 (0.06)	...
RX-31	134.54 (5.297)	11.91 (0.469)	6.45 (0.254)	4.24 (0.167)	25.40 (1.000)	1.5 (0.06)	...
RX-35	147.24 (5.797)	11.91 (0.469)	6.45 (0.254)	4.24 (0.167)	25.40 (1.000)	1.5 (0.06)	...
RX-37	159.94 (6.297)	11.91 (0.469)	6.45 (0.254)	4.24 (0.167)	25.40 (1.000)	1.5 (0.06)	...
RX-39	172.64 (6.797)	11.91 (0.469)	6.45 (0.254)	4.24 (0.167)	25.40 (1.000)	1.5 (0.06)	...
RX-41	191.69 (7.547)	11.91 (0.469)	6.45 (0.254)	4.24 (0.167)	25.40 (1.000)	1.5 (0.06)	...
RX-44	204.39 (8.047)	11.91 (0.469)	6.45 (0.254)	4.24 (0.167)	25.40 (1.000)	1.5 (0.06)	...
RX-45	221.84 (8.734)	11.91 (0.469)	6.45 (0.254)	4.24 (0.167)	25.40 (1.000)	1.5 (0.06)	...
RX-46	222.25 (8.750)	13.49 (0.531)	6.68 (0.263)	4.78 (0.188)	28.58 (1.125)	1.5 (0.06)	...
RX-47	245.26 (9.656)	19.84 (0.781)	10.34 (0.407)	6.88 (0.271)	41.28 (1.625)	2.3 (0.09)	...
RX-49	280.59 (11.047)	11.91 (0.469)	6.45 (0.254)	4.24 (0.167)	25.40 (1.000)	1.5 (0.06)	...
RX-50	283.36 (11.156)	16.66 (0.656)	8.51 (0.335)	5.28 (0.208)	31.75 (1.250)	1.5 (0.06)	...
RX-53	334.57 (13.172)	11.91 (0.469)	6.45 (0.254)	4.24 (0.167)	25.40 (1.000)	1.5 (0.06)	...
RX-54	337.34 (13.281)	16.66 (0.656)	8.51 (0.335)	5.28 (0.208)	31.75 (1.250)	1.5 (0.06)	...
RX-57	391.72 (15.422)	11.91 (0.469)	6.45 (0.254)	4.24 (0.167)	25.40 (1.000)	1.5 (0.06)	...
RX-63	441.73 (17.391)	27.00 (1.063)	14.78 (0.582)	8.46 (0.333)	50.80 (2.000)	2.3 (0.09)	...
RX-65	480.62 (18.922)	11.91 (0.469)	6.45 (0.254)	4.24 (0.167)	25.40 (1.000)	1.5 (0.06)	...
RX-66	483.39 (19.031)	16.66 (0.656)	8.51 (0.335)	5.28 (0.208)	31.75 (1.250)	1.5 (0.06)	...
RX-69	544.12 (21.422)	11.91 (0.469)	6.45 (0.254)	4.24 (0.167)	25.40 (1.000)	1.5 (0.06)	...
RX-70	550.06 (21.656)	19.84 (0.781)	10.34 (0.407)	6.88 (0.271)	41.28 (1.625)	2.3 (0.09)	...
RX-73	596.11 (23.469)	13.49 (0.531)	6.68 (0.263)	5.28 (0.208)	31.75 (1.250)	1.5 (0.06)	...

Table RJ-5-3 Type RX Ring Gasket Dimensions and Tolerances (Cont'd)

Ring Number	Outside Diameter of Ring, O.D., mm (in.)	Width of Ring, A, mm (in.)	Width of Flat, C, mm (in.)	Height of Outside Bevel, D, mm (in.)	Height of Ring, H, mm (in.)	Radius in Octagonal Ring, R ₁ , mm (in.)	Hole Size, E, mm (in.) [Note (1)]
RX-74	600.86 (23.656)	19.84 (0.781)	10.34 (0.407)	6.88 (0.271)	41.28 (1.625)	2.3 (0.09)	...
RX-82	67.87 (2.672)	11.91 (0.469)	6.45 (0.254)	4.24 (0.167)	25.40 (1.000)	1.5 (0.06)	1.5 (0.06)
RX-84	74.22 (2.922)	11.91 (0.469)	6.45 (0.254)	4.24 (0.167)	25.40 (1.000)	1.5 (0.06)	1.5 (0.06)
RX-85	90.09 (3.547)	13.49 (0.531)	6.68 (0.263)	4.24 (0.167)	25.40 (1.000)	1.5 (0.06)	1.5 (0.06)
RX-86	103.58 (4.078)	15.09 (0.594)	8.51 (0.335)	4.78 (0.188)	28.58 (1.125)	1.5 (0.06)	2.3 (0.09)
RX-87	113.11 (4.453)	15.09 (0.594)	8.51 (0.335)	4.78 (0.188)	28.58 (1.125)	1.5 (0.06)	2.3 (0.09)
RX-88	139.29 (5.484)	17.48 (0.688)	10.34 (0.407)	5.28 (0.208)	31.75 (1.250)	1.5 (0.06)	3.0 (0.12)
RX-89	129.77 (5.109)	18.26 (0.719)	10.34 (0.407)	5.28 (0.208)	31.75 (1.250)	1.5 (0.06)	3.0 (0.12)
RX-90	174.63 (6.875)	19.84 (0.781)	12.17 (0.479)	7.42 (0.292)	44.45 (1.750)	2.3 (0.09)	3.0 (0.12)
RX-91	286.94 (11.297)	30.18 (1.188)	19.81 (0.780)	7.54 (0.297)	45.24 (1.781)	2.3 (0.09)	3.0 (0.12)
RX-99	245.67 (9.672)	11.91 (0.469)	6.45 (0.254)	4.24 (0.167)	25.40 (1.000)	1.5 (0.06)	...
RX-201	51.46 (2.026)	5.74 (0.226)	3.20 (0.126)	1.45 (0.057)	11.30 (0.445)	0.5 (0.02) [Note (2)]	...
RX-205	62.31 (2.453)	5.56 (0.219)	3.05 (0.120)	1.83 (0.072) [Note (3)]	11.10 (0.437)	0.5 (0.02) [Note (2)]	...
RX-210	97.64 (3.844)	9.53 (0.375)	5.41 (0.213)	3.18 (0.125) [Note (3)]	19.05 (0.750)	0.8 (0.03) [Note (2)]	...
RX-215	140.89 (5.547)	11.91 (0.469)	5.33 (0.210)	4.24 (0.167) [Note (3)]	25.40 (1.000)	1.5 (0.06) [Note (2)]	...

GENERAL NOTE: Tolerances:

23 deg = angle, ± 0 deg, 30 min ($\pm 1/2$ deg)

A = width of ring, +0.20 mm, -0.00 mm (+0.008 in., -0 in.)

Variation in width throughout the entire circumference of any ring shall not exceed 0.10 mm (0.004 in.) within these tolerances.

C = width of flat, +0.15 mm, -0.00 mm (+0.006 in., -0 in.)

D = height of outside bevel, +0.0 mm, -0.76 mm (+0 in., -0.030 in.)

E = hole size, ± 0.5 mm (± 0.02 in.)

H = height of ring, +0.20 mm, -0.00 mm (+0.008 in., -0 in.)

Variation in height throughout the entire circumference of any ring shall not exceed 0.10 mm (0.004 in.) within these tolerances.

O.D. = outside diameter of ring, +0.51 mm, -0.00 mm (+0.020 in., -0 in.)

R₁ = radius of ring, ± 0.5 mm (± 0.02 in.)

NOTES:

- (1) Rings RX-82 through RX-91 require only one pressure passage hole as illustrated. The centerline of the hole shall be located at the midpoint of dimension C.
- (2) Tolerance on these dimensions is +0.5 mm, -0.0 mm (+0.02 in., -0 in.).
- (3) Tolerance on these dimensions is +0.00 mm, -0.38 mm (+0 in., -0.015 in.).

Table RJ-5-4 Pipe Sizes for Type RX Ring Gaskets Suitable for Referenced Standards

Ring Number	Pressure Classes, API 6B			
	720-960 and 2000 [Note (1)]	2900 [Note (1)]	3000	5000
RX-20	1½	...	1½	1½
RX-23	2
RX-24	2	2
RX-25	3⅛
RX-26	2½
RX-27	2½	2½
RX-31	3	...	3	...
RX-35	3
RX-37	4	...	4	...
RX-39	4
RX-41	5	...	5	...
RX-44	5
RX-45	6	...	6	...
RX-46	6
RX-47	8 [Note (2)]
RX-49	8	...	8	...
RX-50	8
RX-53	10	...	10	...
RX-54	10
RX-57	12	...	12	...
RX-63	14
RX-65	16
RX-66	16	...
RX-69	18
RX-70	18	...
RX-73	20
RX-74	20	...
RX-82	...	1
RX-84	...	1½
RX-85	...	2
RX-86	...	2½
RX-87	...	3
RX-88	...	4
RX-89	...	3½
RX-90	...	5
RX-91	...	10
RX-99	8 [Note (2)]	...	8 [Note (2)]	...
RX-201	1⅜
RX-205	1⅓ ₁₆
RX-210	2 ⁹ / ₁₆
RX-215	4 ¹ / ₁₆

NOTES:

(1) Class 720, 960, and 2900 flanges to API 6B are obsolete. Data are for information only.

(2) Crossover flange connection.

Table RJ-5-5 Type BX Ring Gasket Dimensions and Tolerances

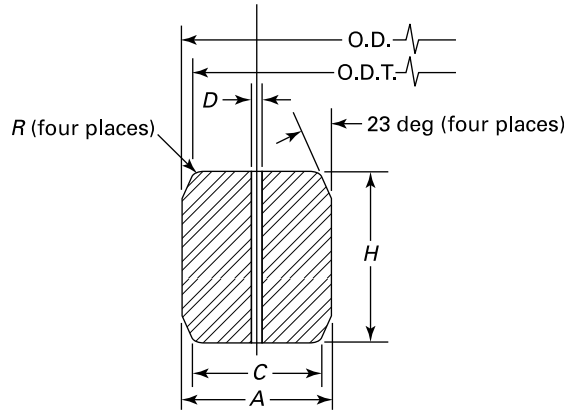

Ring Number	Nominal Size, mm (in.)	Outside Diameter of Ring, O.D., mm (in.)	Height of Ring, H, mm (in.)	Width of Ring, A, mm (in.)	Outside Diameter of Flat, O.D.T., mm (in.)	Width of Flat, C, mm (in.)	Hole Size, D, mm (in.) [Note (1)]
BX-150	43 (1 ¹¹ / ₁₆)	72.19 (2.842)	9.30 (0.366)	9.30 (0.366)	70.87 (2.790)	7.98 (0.314)	1.5 (0.06)
BX-151	46 (1 ¹³ / ₁₆)	76.40 (3.008)	9.63 (0.379)	9.63 (0.379)	75.03 (2.954)	8.26 (0.325)	1.5 (0.06)
BX-152	52 (2 ¹ / ₁₆)	84.68 (3.334)	10.24 (0.403)	10.24 (0.403)	83.24 (3.277)	8.79 (0.346)	1.5 (0.06)
BX-153	65 (2 ⁹ / ₁₆)	100.94 (3.974)	11.38 (0.448)	11.38 (0.448)	99.31 (3.910)	9.78 (0.385)	1.5 (0.06)
BX-154	78 (3 ¹ / ₁₆)	116.84 (4.600)	12.40 (0.488)	12.40 (0.488)	115.09 (4.531)	10.64 (0.419)	1.5 (0.06)
BX-155	103 (4 ¹ / ₁₆)	147.96 (5.825)	14.22 (0.560)	14.22 (0.560)	145.95 (5.746)	12.22 (0.481)	1.5 (0.06)
BX-156	179 (7 ¹ / ₁₆)	237.92 (9.367)	18.62 (0.733)	18.62 (0.733)	235.28 (9.263)	15.98 (0.629)	3.0 (0.12)
BX-157	229 (9)	294.46 (11.593)	20.98 (0.826)	20.98 (0.826)	291.49 (11.476)	18.01 (0.709)	3.0 (0.12)
BX-158	279 (11)	352.04 (13.860)	23.14 (0.911)	23.14 (0.911)	348.77 (13.731)	19.86 (0.782)	3.0 (0.12)
BX-159	346 (13 ⁵ / ₈)	426.72 (16.800)	25.70 (1.012)	25.70 (1.012)	423.09 (16.657)	22.07 (0.869)	3.0 (0.12)
BX-160	346 (13 ⁵ / ₈)	402.59 (15.850)	23.83 (0.938)	13.74 (0.541)	399.21 (15.717)	10.36 (0.408)	3.0 (0.12)
BX-161	422 (16 ⁵ / ₈)	491.41 (19.347)	28.07 (1.105)	16.21 (0.638)	487.45 (19.191)	12.24 (0.482)	3.0 (0.12)
BX-162	422 (16 ⁵ / ₈)	475.49 (18.720)	14.22 (0.560)	14.22 (0.560)	473.48 (18.641)	12.22 (0.481)	1.5 (0.06)
BX-163	476 (18 ³ / ₄)	556.16 (21.896)	30.10 (1.185)	17.37 (0.684)	551.89 (21.728)	13.11 (0.516)	3.0 (0.12)
BX-164	476 (18 ³ / ₄)	570.56 (22.463)	30.10 (1.185)	24.59 (0.968)	566.29 (22.295)	20.32 (0.800)	3.0 (0.12)
BX-165	540 (21 ¹ / ₄)	624.71 (24.595)	32.03 (1.261)	18.49 (0.728)	620.19 (24.417)	13.97 (0.550)	3.0 (0.12)
BX-166	540 (21 ¹ / ₄)	640.03 (25.198)	32.03 (1.261)	26.14 (1.029)	635.51 (25.020)	21.62 (0.851)	3.0 (0.12)
BX-167	680 (26 ³ / ₄)	759.36 (29.896)	35.86 (1.412)	13.11 (0.516)	754.28 (29.696)	8.03 (0.316)	1.5 (0.06)
BX-168	680 (26 ³ / ₄)	765.25 (30.128)	35.86 (1.412)	16.05 (0.632)	760.17 (29.928)	10.97 (0.432)	1.5 (0.06)
BX-169	130 (5 ¹ / ₈)	173.51 (6.831)	15.85 (0.624)	12.93 (0.509)	171.27 (6.743)	10.69 (0.421)	1.5 (0.06)
BX-170	168 (6 ⁵ / ₈)	218.03 (8.584)	14.22 (0.560)	14.22 (0.560)	216.03 (8.505)	12.22 (0.481)	1.5 (0.06)
BX-171	218 (8 ⁹ / ₁₆)	267.44 (10.529)	14.22 (0.560)	14.22 (0.560)	265.43 (10.450)	12.22 (0.481)	1.5 (0.06)
BX-172	283 (11 ⁵ / ₃₂)	333.07 (13.113)	14.22 (0.560)	14.22 (0.560)	331.06 (13.034)	12.22 (0.481)	1.5 (0.06)
BX-303	762 (30)	852.75 (33.573)	37.95 (1.494)	16.97 (0.668)	847.37 (33.361)	11.61 (0.457)	1.5 (0.06)

GENERAL NOTES:

(a) Radius, R , shall be 8% to 12% of the gasket height, H .

(b) Tolerances:

23 deg = angle, ± 0 deg 15 min ($\pm \frac{1}{4}$ deg) A = width of ring, +0.20 mm, -0.00 mm (+0.008 in., -0 in.)

Variation in width throughout the entire circumference of any ring shall not exceed 0.10 mm (0.004 in.) within these tolerances.

 C = width of flat, +0.15 mm, -0.00 mm (+0.006 in., -0 in.) D = hole size, ± 0.5 mm (± 0.02 in.) H = height of ring, +0.20 mm, -0.00 mm (+0.008 in., -0 in.)

Table RJ-5-5 Type BX Ring Gasket Dimensions and Tolerances (Cont'd)

GENERAL NOTES (Cont'd):

- Variation in height throughout the entire circumference of any ring shall not exceed 0.10 mm (0.004 in.) within these tolerances.
- O.D. = outside diameter of ring, +0.00 mm, -0.15 mm (+0 in., -0.005 in.)
- O.D.T. = outside diameter of flat, ±0.05 mm (±0.002 in.)
- R = radius of ring [see General Note (a)]

NOTE: (1) One pressure passage hole is required per gasket as illustrated. The centerline of the hole shall be located at the midpoint of dimension C.

Table RJ-5-6 Pipe Sizes for Type BX Ring Gaskets Suitable for Referenced Standards

Ring Number	Pressure Classes, API 6BX					
	2000	3000	5000	10000	15000	20000
BX-150	1 ¹¹ / ₁₆	1 ¹¹ / ₁₆	...
BX-151	1 ¹³ / ₁₆	1 ¹³ / ₁₆	1 ¹³ / ₁₆
BX-152	2 ¹ / ₁₆	2 ¹ / ₁₆	2 ¹ / ₁₆
BX-153	2 ⁹ / ₁₆	2 ⁹ / ₁₆	2 ⁹ / ₁₆
BX-154	3 ¹ / ₁₆	3 ¹ / ₁₆	3 ¹ / ₁₆
BX-155	4 ¹ / ₁₆	4 ¹ / ₁₆	4 ¹ / ₁₆
BX-156	7 ¹ / ₁₆	7 ¹ / ₁₆	7 ¹ / ₁₆
BX-157	9	9	9
BX-158	11	11	11
BX-159	13 ⁵ / ₈	13 ⁵ / ₈	13 ⁵ / ₈
BX-160	13 ⁵ / ₈
BX-161	16 ³ / ₄
BX-162	16 ³ / ₄	16 ³ / ₄	16 ³ / ₄	...
BX-163	18 ³ / ₄
BX-164	18 ³ / ₄	18 ³ / ₄	...
BX-165	21 ¹ / ₄
BX-166	21 ¹ / ₄
BX-167	26 ³ / ₄
BX-168	...	26 ³ / ₄
BX-169	5 ¹ / ₈
BX-170	6 ⁵ / ₈	6 ⁵ / ₈	...
BX-171	8 ⁹ / ₁₆	8 ⁹ / ₁₆	...
BX-172	11 ⁵ / ₃₂	11 ⁵ / ₃₂	...
BX-303	30	30

PART SW

SPIRAL-WOUND GASKETS

SW-1 SIZE AND CLASS

Spiral-wound gaskets, including centering ring and inner ring (paras. [SW-2.4](#) and [SW-2.5](#)), are identified by flange size (NPS), pressure class, and the appropriate flange standard (ASME B16.5 or ASME B16.47).

SW-2 DIMENSIONS AND TOLERANCES

SW-2.1 General

Dimensions and tolerances for spiral-wound gaskets, centering rings, and inner rings shall be in accordance with [Figure SW-2.1-1](#) and [Tables SW-2.1-1](#) through [SW-2.1-6](#), and as specified in this Part.

(17) SW-2.2 Construction

Spiral-wound gaskets shall be constructed as alternate plies (circular layers counted as revolutions) of preformed metal windings and pliant fillers that are spirally wound.

Pliant fillers shall not extend below the metal winding on both contact faces of the gasket. Metal winding thickness shall be 0.190 mm \pm 0.040 mm (0.0075 in. \pm 0.0015 in.). For all filler materials, filler thickness and density shall be determined by the manufacturer such that the performance testing criteria in [para. SW-2.6](#) will be met. In addition, for gaskets with flexible graphite filler material, filler thickness and density shall be determined by the manufacturer such that each finished gasket will compress to a thickness no less than 3.43 mm (0.135 in.) when subjected to the following uniform gasket stress, and where the gasket contact area is calculated using the inside and outside diameters as shown in [Tables SW-2.1-1](#) through [SW-2.1-3](#):

- (a) 52 MPa (7,500 psi) for Class 150 flanges
- (b) 70 MPa (10,000 psi) for Class 300 through Class 600 flanges
- (c) 140 MPa (20,000 psi) for Class 900 and above flanges

SW-2.3 Metal Joining

The inner windings shall have a minimum of three plies of preformed metal strip without filler. The initial two plies shall have spot welds spaced around the inner circumference. The minimum number of welds shall be three. The maximum distance between welds shall be

76 mm (3.0 in.). The outer windings, which shall have a minimum of three plies of preformed metal without filler, shall be spot-welded circumferentially with a minimum of three welds, the last of which shall be the terminal weld.

The distance of the first weld from the terminal weld shall be no greater than 38 mm (1.5 in.). Up to four additional loose preformed metal windings beyond the terminal weld may be used to retain the gasket into the centering ring.

SW-2.4 Centering Ring

All spiral-wound gaskets shall be furnished assembled into a centering ring. The centering-ring thickness shall be from 2.97 mm to 3.33 mm (0.117 in. to 0.131 in.) and suitably grooved on the inside diameter so as to retain the gasket.

SW-2.5 Inner Ring

Inward buckling of spiral-wound gaskets has been identified as a potential problem. Inner rings shall be furnished with all spiral-wound gaskets having polytetrafluoroethylene (PTFE) filler material. Inner rings for flexible graphite-filled, spiral-wound gaskets shall be furnished unless the purchaser specifies otherwise.

For all filler materials, inner rings shall be furnished in spiral-wound gaskets for

- (a) NPS 24 and larger in Class 900
- (b) NPS 12 and larger in Class 1500
- (c) NPS 4 and larger in Class 2500

Inner rings are required for these gaskets due to high available bolt loads, which may result in outer ring damage.

The inner-ring thickness shall be from 2.97 mm to 3.33 mm (0.117 in. to 0.131 in.).

[Tables SW-2.1-4](#) through [SW-2.1-6](#) show inner-ring inside diameters that may extend a maximum of 1.5 mm (0.06 in.) into the flange bore under the worst combination of flange bore, eccentric installation, and tolerance.

Gaskets with inner rings should be used only with socket welding, lapped, welding neck, and integral flanges. Reference [Table SW-2.5-1](#) for minimum pipewall thickness for use with gaskets with inner rings. Reference [Tables SW-2.5-2](#) through [SW-2.5-4](#) for maximum allowable bore for use with gaskets without inner rings.

(17) SW-2.6 Performance Testing

For all corresponding sizes and pressure classes, finished gaskets (including windings as well as inner and outer rings) shall be capable of meeting a maximum permissible leakage rate of 0.0137 mg/s·m (7.67E-10 lb/sec·in.). The circumferential length [meter (inch)] shall be calculated using the gasket outside diameter as shown in [Tables SW-2.1-1](#) through [SW-2.1-3](#). Testing shall be conducted at ambient temperature using an external calibration gas with a known methane concentration and a test gas flow rate of 1 L/min.

(a) The test fixture shall have a surface finish per ASME B16.5, be capable of shielding the gasket so as to direct any leakage to the monitoring probe, and be capable of applying a uniform load on the test gasket sealing element while internally pressurizing the gasket with methane (minimum 97% purity).

(b) Gasket stress due to the uniformly applied load shall be 35 MPa (5,000 psi) for Class 150, 56 MPa (8,000 psi) for Class 300 and Class 400, and 70 MPa (10,000 psi) for Class 600 and above.

(c) Test pressure shall be 20 bar (290 psi) for Class 150 and 40 bar (580 psi) for Class 300 and above.

(d) Test pressure shall be maintained for a minimum of 4 h, after which time three readings shall be taken at approximately 5-min intervals; the average of these three readings shall be compared to the maximum permissible leakage rate.

SW-3 MATERIALS

Metal windings and filler materials shall be in accordance with [Table SW-3-1](#). The inner-ring material should match the winding material unless the purchaser specifies otherwise. The centering ring may be carbon steel that is painted, metal plated, or otherwise coated to inhibit atmospheric corrosion.

SW-4 MARKING**SW-4.1 General**

The centering ring of each spiral-wound gasket shall be permanently marked. The lettering height shall be a minimum of 2.5 mm (0.1 in.). The following information shall be included with the centering-ring markings:

(a) manufacturer's name or trademark.

(b) flange size (NPS).

(c) pressure class.

(d) winding metal abbreviation (see [Table SW-3-1](#)), except that the abbreviation may be omitted when Type 304 stainless steel is used.

(e) filler material abbreviation (see [Table SW-3-1](#)).

(f) centering- and inner-ring metal abbreviation (see [Table SW-3-1](#)), except that the abbreviation may be omitted when carbon steel is used for the outer ring and Type 304 stainless steel is used for the inner ring.

(g) flange identification. Gaskets intended for ASME B16.47 flanges shall be marked B16.47 A or B16.47 B, as applicable. Gaskets intended for ASME B16.5 flanges need not be so marked. Illustrative marking examples are shown in [Table SW-4.1-1](#).

(h) ASME B16.20 designation.

SW-4.2 Pressure Class

Gaskets suitable for more than one pressure class shall be marked with all applicable classes, as shown in [Table SW-4.1-1](#).

SW-4.3 Color Coding

Spiral-wound gaskets shall be marked with a color code that identifies the windings and filler materials. A continuous color around the outer edge of the centering ring shall identify the winding metal. The color identifying the filler material for NPS 1½ and larger shall have four intermittent stripes spaced approximately 90 deg apart on the outer edge of the centering ring. Smaller size gaskets shall have a minimum of two stripes 180 deg apart. The colors shall conform to those listed in [Table SW-3-1](#).

(17)

Figure SW-2.1-1 Spiral-Wound Gasket

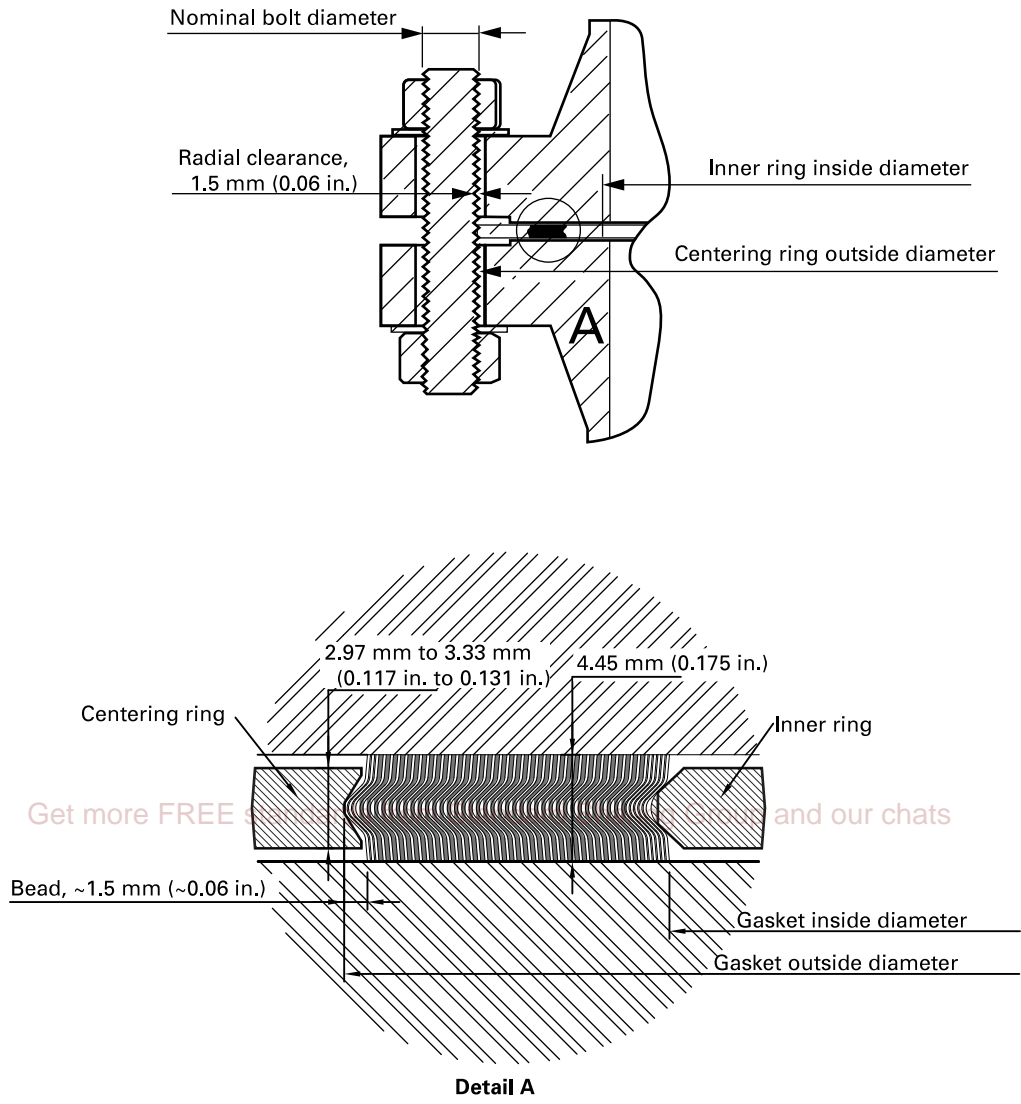

(17)

Table SW-2.1-1 Dimensions for Spiral-Wound Gaskets Used With ASME B16.5 Flanges

SI Units, mm																
Flange Size (NPS)	Outside Diameter of Gasket [Note (1)]		Inside Diameter of Gasket by Class [Notes (2), (3)]								Outside Diameter of Centering Ring by Class [Note (4)]					
	Classes 150, 300, 400, 600	Classes 900, 1500, 2500	150	300	400	600	900	1500	2500	150	300	400	600	900	1500	2500
	1/2	31.8	31.8	19.1	19.1	[Note (5)]	19.1	[Note (5)]	19.1	19.1	47.8	54.1	[Note (5)]	54.1	[Note (5)]	63.5
3/4	39.6	39.6	25.4	25.4	[Note (5)]	25.4	[Note (5)]	25.4	25.4	57.2	66.8	[Note (5)]	66.8	[Note (5)]	69.9	76.2
1	47.8	47.8	31.8	31.8	[Note (5)]	31.8	[Note (5)]	31.8	31.8	66.8	73.2	[Note (5)]	73.2	[Note (5)]	79.5	85.9
1 1/4	60.5	60.5	47.8	47.8	[Note (5)]	47.8	[Note (5)]	39.6	39.6	76.2	82.6	[Note (5)]	82.6	[Note (5)]	88.9	104.9
1 1/2	69.9	69.9	54.1	54.1	[Note (5)]	54.1	[Note (5)]	47.8	47.8	85.9	95.3	[Note (5)]	95.3	[Note (5)]	98.6	117.6
2	85.9	85.9	69.9	69.9	[Note (5)]	69.9	[Note (5)]	58.7	58.7	104.9	111.3	[Note (5)]	111.3	[Note (5)]	143.0	146.1
2 1/2	98.6	98.6	82.6	82.6	[Note (5)]	82.6	[Note (5)]	69.9	69.9	124.0	130.3	[Note (5)]	130.3	[Note (5)]	165.1	168.4
3	120.7	120.7	101.6	101.6	[Note (5)]	101.6	95.3	92.2	92.2	136.7	149.4	[Note (5)]	149.4	168.4	174.8	196.9
3 1/2	133.4	[Note (5)]	114.3	114.3	[Note (5)]	104.8	[Note (5)]	[Note (5)]	[Note (5)]	161.9	165.1	[Note (5)]	161.9	[Note (5)]	[Note (5)]	[Note (5)]
4	149.4	149.4	127.0	127.0	120.7	120.7	120.7	117.6	117.6	174.8	181.1	177.8	193.8	206.5	209.6	235.0
5	177.8	177.8	155.7	155.7	147.6	147.6	147.6	143.0	143.0	196.9	215.9	212.9	241.3	247.7	254.0	279.4
6	209.6	209.6	182.6	182.6	174.8	174.8	174.8	171.5	171.5	222.3	251.0	247.7	266.7	289.1	282.7	317.5
8	263.7	257.3	233.4	233.4	225.6	225.6	222.3	215.9	215.9	279.4	308.1	304.8	320.8	358.9	352.6	387.4
10	317.5	311.2	287.3	287.3	274.6	274.6	276.4	266.7	270.0	339.9	362.0	358.9	400.1	435.1	435.1	476.3
12	374.7	368.3	339.9	339.9	327.2	327.2	323.9	323.9	317.5	409.7	422.4	419.1	457.2	498.6	520.7	549.4
14	406.4	400.1	371.6	371.6	362.0	362.0	355.6	362.0	[Note (5)]	450.9	485.9	482.6	492.3	520.7	577.9	[Note (5)]
16	463.6	457.2	422.4	422.4	412.8	412.8	412.8	406.4	[Note (5)]	514.4	539.8	536.7	565.2	574.8	641.4	[Note (5)]
18	527.1	520.7	474.7	474.7	469.9	469.9	463.6	463.6	[Note (5)]	549.4	596.9	593.9	612.9	638.3	704.9	[Note (5)]
20	577.9	571.5	525.5	525.5	520.7	520.7	520.7	514.4	[Note (5)]	606.6	654.1	647.7	682.8	698.5	755.7	[Note (5)]
24	685.8	679.5	628.7	628.7	628.7	628.7	628.7	616.0	[Note (5)]	717.6	774.7	768.4	790.7	838.2	901.7	[Note (5)]

18

ASME B16.20-2017

U.S. Customary Units, in.																
Flange Size (NPS)	Outside Diameter of Gasket [Note (1)]		Inside Diameter of Gasket by Class [Notes (2), (3)]								Outside Diameter of Centering Ring by Class [Note (4)]					
	Classes 150, 300, 400, 600	Classes 900, 1500, 2500	150	300	400	600	900	1500	2500	150	300	400	600	900	1500	2500
	1/2	1.25	1.25	0.75	0.75	[Note (5)]	0.75	[Note (5)]	0.75	0.75	1.88	2.13	[Note (5)]	2.13	[Note (5)]	2.50
3/4	1.56	1.56	1.00	1.00	[Note (5)]	1.00	[Note (5)]	1.00	1.00	2.25	2.63	[Note (5)]	2.63	[Note (5)]	2.75	3.00
1	1.88	1.88	1.25	1.25	[Note (5)]	1.25	[Note (5)]	1.25	1.25	2.63	2.88	[Note (5)]	2.88	[Note (5)]	3.13	3.38

(17)

Table SW-2.1-1 Dimensions for Spiral-Wound Gaskets Used With ASME B16.5 Flanges (Cont'd)

U.S. Customary Units, in.																
Flange Size (NPS)	Outside Diameter of Gasket [Note (1)]		Inside Diameter of Gasket by Class [Notes (2), (3)]								Outside Diameter of Centering Ring by Class [Note (4)]					
	Classes 150, 300, 400, 600	Classes 900, 1500, 2500	150	300	400	600	900	1500	2500	150	300	400	600	900	1500	2500
	1¼	2.38	2.38	1.88	1.88	[Note (5)]	1.88	[Note (5)]	1.56	1.56	3.00	3.25	[Note (5)]	3.25	[Note (5)]	3.50
1½	2.75	2.75	2.13	2.13	[Note (5)]	2.13	[Note (5)]	1.88	1.88	3.38	3.75	[Note (5)]	3.75	[Note (5)]	3.88	4.63
2	3.38	3.38	2.75	2.75	[Note (5)]	2.75	[Note (5)]	2.31	2.31	4.13	4.38	[Note (5)]	4.38	[Note (5)]	5.63	5.75
2½	3.88	3.88	3.25	3.25	[Note (5)]	3.25	[Note (5)]	2.75	2.75	4.88	5.13	[Note (5)]	5.13	[Note (5)]	6.50	6.63
3	4.75	4.75	4.00	4.00	[Note (5)]	4.00	3.75	3.63	3.63	5.38	5.88	[Note (5)]	5.88	6.63	6.88	7.75
3½	5.25	[Note (5)]	4.50	4.50	[Note (5)]	4.13	[Note (5)]	[Note (5)]	[Note (5)]	6.38	6.50	[Note (5)]	6.38	[Note (5)]	[Note (5)]	[Note (5)]
4	5.88	5.88	5.00	5.00	4.75	4.75	4.75	4.63	4.63	6.88	7.13	7.00	7.63	8.13	8.25	9.25
5	7.00	7.00	6.13	6.13	5.81	5.81	5.81	5.63	5.63	7.75	8.50	8.38	9.50	9.75	10.00	11.00
6	8.25	8.25	7.19	7.19	6.88	6.88	6.88	6.75	6.75	8.75	9.88	9.75	10.50	11.38	11.13	12.50
8	10.38	10.13	9.19	9.19	8.88	8.88	8.75	8.50	8.50	11.00	12.13	12.00	12.63	14.13	13.88	15.25
10	12.50	12.25	11.31	11.31	10.81	10.81	10.88	10.50	10.63	13.38	14.25	14.13	15.75	17.13	17.13	18.75
12	14.75	14.50	13.38	13.38	12.88	12.88	12.75	12.75	12.50	16.13	16.63	16.50	18.00	19.63	20.50	21.63
14	16.00	15.75	14.63	14.63	14.25	14.25	14.00	14.25	[Note (5)]	17.75	19.13	19.00	19.38	20.50	22.75	[Note (5)]
16	18.25	18.00	16.63	16.63	16.25	16.25	16.25	16.00	[Note (5)]	20.25	21.25	21.13	22.25	22.63	25.25	[Note (5)]
18	20.75	20.50	18.69	18.69	18.50	18.50	18.25	18.25	[Note (5)]	21.63	23.50	23.38	24.13	25.13	27.75	[Note (5)]
20	22.75	22.50	20.69	20.69	20.50	20.50	20.50	20.25	[Note (5)]	23.88	25.75	25.50	26.88	27.50	29.75	[Note (5)]
24	27.00	26.75	24.75	24.75	24.75	24.75	24.75	24.25	[Note (5)]	28.25	30.50	30.25	31.13	33.00	35.50	[Note (5)]

GENERAL NOTES:

- (a) For reference, see [Figure SW-2.1-1](#).
 (b) The gasket thickness tolerance is ± 0.13 mm (± 0.005 in.) measured across the metallic portion of the gasket, not including the filler, which may protrude slightly beyond the metal.
 (c) For limitations on the maximum flange bore for use with these spiral-wound gaskets, see [Table SW-2.5-2](#).

NOTES:

- (1) The gasket outside diameter tolerance for NPS ½ through NPS 8 is ± 0.8 mm (± 0.03 in.); for NPS 10 through NPS 24, +1.5 mm, -0.8 mm (+0.06 in., -0.03 in.).
 (2) Refer to [para. SW-2.5](#) for required use of inner rings.
 (3) The gasket inside diameter tolerance for NPS ½ through NPS 8 is ± 0.4 mm (± 0.016 in.); for NPS 10 through NPS 24, ± 0.8 mm (± 0.03 in.).
 (4) The centering-ring outside diameter tolerance is ± 0.8 mm (± 0.03 in.).
 (5) There are no Class 400 flanges in NPS ½ through NPS 3½ (use Class 600); Class 900 flanges in NPS ½ through NPS 2½ or in NPS 3½ (use Class 1500); Class 1500 flanges in NPS 3½; or Class 2500 flanges in NPS 3½ or NPS 14 and larger.

(17)

Table SW-2.1-2 Dimensions for Spiral-Wound Gaskets Used With ASME B16.47 Series A Flanges

SI Units, mm															
Flange Size (NPS)	Class 150			Class 300			Class 400			Class 600			Class 900		
	Gasket		Centering-Ring Outside Diameter [Note (4)]	Gasket		Centering-Ring Outside Diameter [Note (4)]	Gasket		Centering-Ring Outside Diameter [Note (4)]	Gasket		Centering-Ring Outside Diameter [Note (4)]	Gasket		Centering-Ring Outside Diameter [Note (4)]
	Inside Diameter [Notes (1), (2)]	Outside Diameter [Note (3)]		Inside Diameter [Notes (1), (2)]	Outside Diameter [Note (3)]		Inside Diameter [Notes (1), (2)]	Outside Diameter [Note (3)]		Inside Diameter [Notes (1), (2)]	Outside Diameter [Note (3)]		Inside Diameter [Notes (1), (2)]	Outside Diameter [Note (3)]	
26	673.1	704.9	774.7	685.8	736.6	835.2	685.8	736.6	831.9	685.8	736.6	866.9	685.8	736.6	882.7
28	723.9	755.7	831.9	736.6	787.4	898.7	736.6	787.4	892.3	736.6	787.4	914.4	736.6	787.4	946.2
30	774.7	806.5	882.7	793.8	844.6	952.5	793.8	844.6	946.2	793.8	844.6	971.6	793.8	844.6	1 009.7
32	825.5	860.6	939.8	850.9	901.7	1 006.6	850.9	901.7	1 003.3	850.9	901.7	1 022.4	850.9	901.7	1 073.2
34	876.3	911.4	990.6	901.7	952.5	1 057.4	901.7	952.5	1 054.1	901.7	952.5	1 073.2	901.7	952.5	1 136.7
36	927.1	968.5	1 047.8	955.8	1 006.6	1 117.6	955.8	1 006.6	1 117.6	955.8	1 006.6	1 130.3	958.9	1 009.7	1 200.2
38	977.9	1 019.3	1 111.3	977.9	1 016.0	1 054.1	971.6	1 022.4	1 073.2	990.6	1 041.4	1 104.9	1 035.1	1 085.9	1 200.2
40	1 028.7	1 070.1	1 162.1	1 022.4	1 070.1	1 114.6	1 025.7	1 076.5	1 127.3	1 047.8	1 098.6	1 155.7	1 098.6	1 149.4	1 251.0
42	1 079.5	1 124.0	1 219.2	1 073.2	1 120.9	1 165.4	1 076.5	1 127.3	1 178.1	1 104.9	1 155.7	1 219.2	1 149.4	1 200.2	1 301.8
44	1 130.3	1 178.1	1 276.4	1 130.3	1 181.1	1 219.2	1 130.3	1 181.1	1 231.9	1 162.1	1 212.9	1 270.0	1 206.5	1 257.3	1 368.6
46	1 181.1	1 228.9	1 327.2	1 178.1	1 228.9	1 273.3	1 193.8	1 244.6	1 289.1	1 212.9	1 263.7	1 327.2	1 270.0	1 320.8	1 435.1
48	1 231.9	1 279.7	1 384.3	1 235.2	1 286.0	1 324.1	1 244.6	1 295.4	1 346.2	1 270.0	1 320.8	1 390.7	1 320.8	1 371.6	1 485.9
50	1 282.7	1 333.5	1 435.1	1 295.4	1 346.2	1 378.0	1 295.4	1 346.2	1 403.4	1 320.8	1 371.6	1 447.8	[Note (5)]	[Note (5)]	[Note (5)]
52	1 333.5	1 384.3	1 492.3	1 346.2	1 397.0	1 428.8	1 346.2	1 397.0	1 454.2	1 371.6	1 422.4	1 498.6	[Note (5)]	[Note (5)]	[Note (5)]
54	1 384.3	1 435.1	1 549.4	1 403.4	1 454.2	1 492.3	1 403.4	1 454.2	1 517.7	1 428.8	1 479.6	1 555.8	[Note (5)]	[Note (5)]	[Note (5)]
56	1 435.1	1 485.9	1 606.6	1 454.2	1 505.0	1 543.1	1 454.2	1 505.0	1 568.5	1 479.6	1 530.4	1 612.9	[Note (5)]	[Note (5)]	[Note (5)]
58	1 485.9	1 536.7	1 663.7	1 511.3	1 562.1	1 593.9	1 505.0	1 555.8	1 619.3	1 536.7	1 587.5	1 663.7	[Note (5)]	[Note (5)]	[Note (5)]
60	1 536.7	1 587.5	1 714.5	1 562.1	1 612.9	1 644.7	1 568.5	1 619.3	1 682.8	1 593.9	1 644.7	1 733.6	[Note (5)]	[Note (5)]	[Note (5)]
U.S. Customary Units, in.															
Flange Size (NPS)	Class 150			Class 300			Class 400			Class 600			Class 900		
	Gasket		Centering-Ring Outside Diameter [Note (4)]	Gasket		Centering-Ring Outside Diameter [Note (4)]	Gasket		Centering-Ring Outside Diameter [Note (4)]	Gasket		Centering-Ring Outside Diameter [Note (4)]	Gasket		Centering-Ring Outside Diameter [Note (4)]
	Inside Diameter [Notes (1), (2)]	Outside Diameter [Note (3)]		Inside Diameter [Notes (1), (2)]	Outside Diameter [Note (3)]		Inside Diameter [Notes (1), (2)]	Outside Diameter [Note (3)]		Inside Diameter [Notes (1), (2)]	Outside Diameter [Note (3)]		Inside Diameter [Notes (1), (2)]	Outside Diameter [Note (3)]	
26	26.50	27.75	30.50	27.00	29.00	32.88	27.00	29.00	32.75	27.00	29.00	34.13	27.00	29.00	34.75
28	28.50	29.75	32.75	29.00	31.00	35.38	29.00	31.00	35.13	29.00	31.00	36.00	29.00	31.00	37.25
30	30.50	31.75	34.75	31.25	33.25	37.50	31.25	33.25	37.25	31.25	33.25	38.25	31.25	33.25	39.75
32	32.50	33.88	37.00	33.50	35.50	39.63	33.50	35.50	39.50	33.50	35.50	40.25	33.50	35.50	42.25
34	34.50	35.88	39.00	35.50	37.50	41.63	35.50	37.50	41.50	35.50	37.50	42.25	35.50	37.50	44.75
36	36.50	38.13	41.25	37.63	39.63	44.00	37.63	39.63	44.00	37.63	39.63	44.50	37.75	39.75	47.25

20

ASME B16.20-2017

(17)

Table SW-2.1-2 Dimensions for Spiral-Wound Gaskets Used With ASME B16.47 Series A Flanges (Cont'd)

U.S. Customary Units, in.																
Flange Size (NPS)	Class 150			Class 300			Class 400			Class 600			Class 900			
	Gasket		Centering- Ring Outside Diameter [Note (4)]	Gasket		Centering- Ring Outside Diameter [Note (4)]	Gasket		Centering- Ring Outside Diameter [Note (4)]	Gasket		Centering- Ring Outside Diameter [Note (4)]	Gasket		Centering- Ring Outside Diameter [Note (4)]	
	Inside Diameter [Notes (1), (2)]	Outside Diameter [Note (3)]		Inside Diameter [Notes (1), (2)]	Outside Diameter [Note (3)]		Inside Diameter [Notes (1), (2)]	Outside Diameter [Note (3)]		Inside Diameter [Notes (1), (2)]	Outside Diameter [Note (3)]		Inside Diameter [Notes (1), (2)]	Outside Diameter [Note (3)]		
	38	38.50	40.13	43.75	38.50	40.00	41.50	38.25	40.25	42.25	39.00	41.00	43.50	40.75	42.75	47.25
40	40.50	42.13	45.75	40.25	42.13	43.88	40.38	42.38	44.38	41.25	43.25	45.50	43.25	45.25	49.25	
42	42.50	44.25	48.00	42.25	44.13	45.88	42.38	44.38	46.38	43.50	45.50	48.00	45.25	47.25	51.25	
44	44.50	46.38	50.25	44.50	46.50	48.00	44.50	46.50	48.50	45.75	47.75	50.00	47.50	49.50	53.88	
46	46.50	48.38	52.25	46.38	48.38	50.13	47.00	49.00	50.75	47.75	49.75	52.25	50.00	52.00	56.50	
48	48.50	50.38	54.50	48.63	50.63	52.13	49.00	51.00	53.00	50.00	52.00	54.75	52.00	54.00	58.50	
50	50.50	52.50	56.50	51.00	53.00	54.25	51.00	53.00	55.25	52.00	54.00	57.00	[Note (5)]	[Note (5)]	[Note (5)]	
52	52.50	54.50	58.75	53.00	55.00	56.25	53.00	55.00	57.25	54.00	56.00	59.00	[Note (5)]	[Note (5)]	[Note (5)]	
54	54.50	56.50	61.00	55.25	57.25	58.75	55.25	57.25	59.75	56.25	58.25	61.25	[Note (5)]	[Note (5)]	[Note (5)]	
56	56.50	58.50	63.25	57.25	59.25	60.75	57.25	59.25	61.75	58.25	60.25	63.50	[Note (5)]	[Note (5)]	[Note (5)]	
58	58.50	60.50	65.50	59.50	61.50	62.75	59.25	61.25	63.75	60.50	62.50	65.50	[Note (5)]	[Note (5)]	[Note (5)]	
60	60.50	62.50	67.50	61.50	63.50	64.75	61.75	63.75	66.25	62.75	64.75	68.25	[Note (5)]	[Note (5)]	[Note (5)]	

GENERAL NOTES:

- (a) For reference, see [Figure SW-2.1-1](#).
 (b) The gasket thickness tolerance is ± 0.13 mm (± 0.005 in.) measured across the metallic portion of the gasket, not including the filler, which may protrude slightly beyond the metal.
 (c) For limitations on the maximum flange bore for use with these spiral-wound gaskets, see [Table SW-2.5-3](#).

NOTES:

- (1) Refer to [para. SW-2.5](#) for required use of inner rings.
 (2) The gasket inside diameter tolerance for NPS 26 through NPS 34 is ± 0.8 mm (± 0.03 in.), and the tolerance for NPS 36 through NPS 60 is ± 1.5 mm (± 0.06 in.).
 (3) The gasket outside diameter tolerance for NPS 26 through NPS 60 is ± 1.5 mm (± 0.06 in.).
 (4) The centering-ring outside diameter tolerance is ± 0.8 mm (± 0.03 in.).
 (5) There are no Class 900 flanges in NPS 50 and larger.

(17)

Table SW-2.1-3 Dimensions for Spiral-Wound Gaskets Used With ASME B16.47 Series B Flanges

SI Units, mm															
Flange Size (NPS)	Class 150			Class 300			Class 400			Class 600			Class 900		
	Gasket		Centering-Ring Outside Diameter [Note (4)]	Gasket		Centering-Ring Outside Diameter [Note (4)]	Gasket		Centering-Ring Outside Diameter [Note (4)]	Gasket		Centering-Ring Outside Diameter [Note (4)]	Gasket		Centering-Ring Outside Diameter [Note (4)]
	Inside Diameter [Notes (1), (2)]	Outside Diameter [Note (3)]		Inside Diameter [Notes (1), (2)]	Outside Diameter [Note (3)]		Inside Diameter [Notes (1), (2)]	Outside Diameter [Note (3)]		Inside Diameter [Notes (1), (2)]	Outside Diameter [Note (3)]		Inside Diameter [Notes (1), (2)]	Outside Diameter [Note (3)]	
26	673.1	698.5	725.4	673.1	711.2	771.7	666.8	698.5	746.3	663.7	714.5	765.3	692.2	749.3	838.2
28	723.9	749.3	776.2	723.9	762.0	825.5	714.5	749.3	800.1	704.9	755.7	819.2	743.0	800.1	901.7
30	774.7	800.1	827.0	774.7	812.8	886.0	765.3	806.5	857.3	778.0	828.8	879.6	806.5	857.3	958.9
32	825.5	850.9	881.1	825.5	863.6	939.8	812.8	860.6	911.4	831.9	882.7	933.5	863.6	914.4	1 016.0
34	876.3	908.1	935.0	876.3	914.4	993.9	866.9	911.4	962.2	889.0	939.8	997.0	920.8	971.6	1 073.2
36	927.1	958.9	987.6	927.1	965.2	1 047.8	917.7	965.2	1 022.4	939.8	990.6	1 047.8	946.2	997.0	1 124.0
38	974.9	1 009.7	1 044.7	1 009.7	1 047.8	1 098.6	971.6	1 022.4	1 073.2	990.6	1 041.4	1 104.9	1 035.1	1 085.9	1 200.2
40	1 022.4	1 063.8	1 095.5	1 060.5	1 098.6	1 149.4	1 025.7	1 076.5	1 127.3	1 047.8	1 098.6	1 155.7	1 098.6	1 149.4	1 251.0
42	1 079.5	1 114.6	1 146.3	1 111.3	1 149.4	1 200.2	1 076.5	1 127.3	1 178.1	1 104.9	1 155.7	1 219.2	1 149.4	1 200.2	1 301.8
44	1 124.0	1 165.4	1 197.1	1 162.1	1 200.2	1 251.0	1 130.3	1 181.1	1 231.9	1 162.1	1 212.9	1 270.0	1 206.5	1 257.3	1 368.6
46	1 181.1	1 224.0	1 255.8	1 216.2	1 254.3	1 317.8	1 193.8	1 244.6	1 289.1	1 212.9	1 263.7	1 327.2	1 270.0	1 320.8	1 435.1
48	1 231.9	1 270.0	1 306.6	1 263.7	1 311.4	1 368.6	1 244.6	1 295.4	1 346.2	1 270.0	1 320.8	1 390.7	1 320.8	1 371.6	1 485.9
50	1 282.7	1 325.6	1 357.4	1 317.8	1 355.9	1 419.4	1 295.4	1 346.2	1 403.4	1 320.8	1 371.6	1 447.8	[Note (5)]	[Note (5)]	[Note (5)]
52	1 333.5	1 376.4	1 408.2	1 368.6	1 406.7	1 470.2	1 346.2	1 397.0	1 454.2	1 371.6	1 422.4	1 498.6	[Note (5)]	[Note (5)]	[Note (5)]
54	1 384.3	1 422.4	1 463.8	1 403.4	1 454.2	1 530.4	1 403.4	1 454.2	1 517.7	1 428.8	1 479.6	1 555.8	[Note (5)]	[Note (5)]	[Note (5)]
56	1 444.8	1 478.0	1 514.6	1 479.6	1 524.0	1 593.9	1 454.2	1 505.0	1 568.5	1 479.6	1 530.4	1 612.9	[Note (5)]	[Note (5)]	[Note (5)]
58	1 500.1	1 528.8	1 579.6	1 535.2	1 573.3	1 655.8	1 505.0	1 555.8	1 619.3	1 536.7	1 587.5	1 663.7	[Note (5)]	[Note (5)]	[Note (5)]
60	1 557.3	1 586.0	1 630.4	1 589.0	1 630.4	1 706.6	1 568.5	1 619.3	1 682.8	1 593.9	1 644.7	1 733.6	[Note (5)]	[Note (5)]	[Note (5)]
U.S. Customary Units, in.															
Flange Size (NPS)	Class 150			Class 300			Class 400			Class 600			Class 900		
	Gasket		Centering-Ring Outside Diameter [Note (4)]	Gasket		Centering-Ring Outside Diameter [Note (4)]	Gasket		Centering-Ring Outside Diameter [Note (4)]	Gasket		Centering-Ring Outside Diameter [Note (4)]	Gasket		Centering-Ring Outside Diameter [Note (4)]
	Inside Diameter [Notes (1), (2)]	Outside Diameter [Note (3)]		Inside Diameter [Notes (1), (2)]	Outside Diameter [Note (3)]		Inside Diameter [Notes (1), (2)]	Outside Diameter [Note (3)]		Inside Diameter [Notes (1), (2)]	Outside Diameter [Note (3)]		Inside Diameter [Notes (1), (2)]	Outside Diameter [Note (3)]	
26	26.50	27.50	28.56	26.50	28.00	30.38	26.25	27.50	29.38	26.13	28.13	30.13	27.25	29.50	33.00
28	28.50	29.50	30.56	28.50	30.00	32.50	28.13	29.50	31.50	27.75	29.75	32.25	29.25	31.50	35.50
30	30.50	31.50	32.56	30.50	32.00	34.88	30.13	31.75	33.75	30.63	32.63	34.63	31.75	33.75	37.75
32	32.50	33.50	34.69	32.50	34.00	37.00	32.00	33.88	35.88	32.75	34.75	36.75	34.00	36.00	40.00
34	34.50	35.75	36.81	34.50	36.00	39.13	34.13	35.88	37.88	35.00	37.00	39.25	36.25	38.25	42.25
36	36.50	37.75	38.88	36.50	38.00	41.25	36.13	38.00	40.25	37.00	39.00	41.25	37.25	39.25	44.25

22

ASME B16.20-2017

(17)

Table SW-2.1-3 Dimensions for Spiral-Wound Gaskets Used With ASME B16.47 Series B Flanges (Cont'd)

U.S. Customary Units, in.																
Flange Size (NPS)	Class 150			Class 300			Class 400			Class 600			Class 900			
	Gasket		Centering-Ring Outside Diameter [Note (4)]	Gasket		Centering-Ring Outside Diameter [Note (4)]	Gasket		Centering-Ring Outside Diameter [Note (4)]	Gasket		Centering-Ring Outside Diameter [Note (4)]	Gasket		Centering-Ring Outside Diameter [Note (4)]	
	Inside Diameter [Notes (1), (2)]	Outside Diameter [Note (3)]		Inside Diameter [Notes (1), (2)]	Outside Diameter [Note (3)]		Inside Diameter [Notes (1), (2)]	Outside Diameter [Note (3)]		Inside Diameter [Notes (1), (2)]	Outside Diameter [Note (3)]		Inside Diameter [Notes (1), (2)]	Outside Diameter [Note (3)]		
38	38.38	39.75	41.13	39.75	41.25	43.25	38.25	40.25	42.25	39.00	41.00	43.50	40.75	42.75	47.25	
40	40.25	41.88	43.13	41.75	43.25	45.25	40.38	42.38	44.38	41.25	43.25	45.50	43.25	45.25	49.25	
42	42.50	43.88	45.13	43.75	45.25	47.25	42.38	44.38	46.38	43.50	45.50	48.00	45.25	47.25	51.25	
44	44.25	45.88	47.13	45.75	47.25	49.25	44.50	46.50	48.50	45.75	47.75	50.00	47.50	49.50	53.88	
46	46.50	48.19	49.44	47.88	49.38	51.88	47.00	49.00	50.75	47.75	49.75	52.25	50.00	52.00	56.50	
48	48.50	50.00	51.44	49.75	51.63	53.88	49.00	51.00	53.00	50.00	52.00	54.75	52.00	54.00	58.50	
50	50.50	52.19	53.44	51.88	53.38	55.88	51.00	53.00	55.25	52.00	54.00	57.00	[Note (5)]	[Note (5)]	[Note (5)]	
52	52.50	54.19	55.44	53.88	55.38	57.88	53.00	55.00	57.25	54.00	56.00	59.00	[Note (5)]	[Note (5)]	[Note (5)]	
54	54.50	56.00	57.63	55.25	57.25	60.25	55.25	57.25	59.75	56.25	58.25	61.25	[Note (5)]	[Note (5)]	[Note (5)]	
56	56.88	58.19	59.63	58.25	60.00	62.75	57.25	59.25	61.75	58.25	60.25	63.50	[Note (5)]	[Note (5)]	[Note (5)]	
58	59.06	60.19	62.19	60.44	61.94	65.19	59.25	61.25	63.75	60.50	62.50	65.50	[Note (5)]	[Note (5)]	[Note (5)]	
60	61.31	62.44	64.19	62.56	64.19	67.19	61.75	63.75	66.25	62.75	64.75	68.25	[Note (5)]	[Note (5)]	[Note (5)]	

GENERAL NOTES:

- (a) For reference, see [Figure SW-2.1-1](#).
 (b) The gasket thickness tolerance is ± 0.13 mm (± 0.005 in.) measured across the metallic portion of the gasket, not including the filler, which may protrude slightly beyond the metal.
 (c) For limitations on the maximum flange bore for use with these spiral-wound gaskets, see [Table SW-2.5-4](#).

NOTES:

- (1) Refer to [para. SW-2.5](#) for required use of inner rings.
 (2) The gasket inside diameter tolerance for NPS 26 through NPS 34 is ± 0.8 mm (± 0.03 in.), and the tolerance for NPS 36 through NPS 60 is ± 1.5 mm (± 0.06 in.).
 (3) The gasket outside diameter tolerance for NPS 26 through NPS 60 is ± 1.5 mm (± 0.06 in.).
 (4) The centering-ring outside diameter tolerance is ± 0.8 mm (± 0.03 in.).
 (5) There are no Class 900 flanges in NPS 50 and larger.

(17) **Table SW-2.1-4 Inside Diameters of Inner Rings for Spiral-Wound Gaskets for Use With ASME B16.5 Flanges**

Flange Size (NPS)	Inside Diameter of Inner Ring by Pressure Class, mm (in.)						
	150	300	400	600	900	1500	2500
1/2	14.2 (0.56)	14.2 (0.56)	[Note (1)]	14.2 (0.56)	[Note (1)]	14.2 (0.56)	14.2 (0.56)
3/4	20.6 (0.81)	20.6 (0.81)	[Note (1)]	20.6 (0.81)	[Note (1)]	20.6 (0.81)	20.6 (0.81)
1	26.9 (1.06)	26.9 (1.06)	[Note (1)]	26.9 (1.06)	[Note (1)]	26.9 (1.06)	26.9 (1.06)
1 1/4	38.1 (1.50)	38.1 (1.50)	[Note (1)]	38.1 (1.50)	[Note (1)]	33.3 (1.31)	33.3 (1.31)
1 1/2	44.5 (1.75)	44.5 (1.75)	[Note (1)]	44.5 (1.75)	[Note (1)]	41.4 (1.63)	41.4 (1.63)
2	55.6 (2.19)	55.6 (2.19)	[Note (1)]	55.6 (2.19)	[Note (1)]	52.3 (2.06)	52.3 (2.06)
2 1/2	66.5 (2.62)	66.5 (2.62)	[Note (1)]	66.5 (2.62)	[Note (1)]	63.5 (2.50)	63.5 (2.50)
3	81.0 (3.19)	81.0 (3.19)	[Note (1)]	81.0 (3.19)	78.7 (3.10)	78.7 (3.10)	78.7 (3.10)
3 1/2	101.1 (3.98)	101.1 (3.98)	[Note (1)]	91.4 (3.60)	[Note (1)]	[Note (1)]	[Note (1)]
4	106.4 (4.19)	106.4 (4.19)	102.6 (4.04)	102.6 (4.04)	102.6 (4.04)	97.8 (3.85)	97.8 (3.85)
5	131.8 (5.19)	131.8 (5.19)	128.3 (5.05)	128.3 (5.05)	128.3 (5.05)	124.5 (4.90)	124.5 (4.90)
6	157.2 (6.19)	157.2 (6.19)	154.9 (6.10)	154.9 (6.10)	154.9 (6.10)	147.3 (5.80)	147.3 (5.80)
8	215.9 (8.50)	215.9 (8.50)	205.7 (8.10)	205.7 (8.10)	196.9 (7.75)	196.9 (7.75)	196.9 (7.75)
10	268.2 (10.56)	268.2 (10.56)	255.3 (10.05)	255.3 (10.05)	246.1 (9.69)	246.1 (9.69)	246.1 (9.69)
12	317.5 (12.50)	317.5 (12.50)	307.3 (12.10)	307.3 (12.10)	292.1 (11.50)	292.1 (11.50)	292.1 (11.50)
14	349.3 (13.75)	349.3 (13.75)	342.9 (13.50)	342.9 (13.50)	320.8 (12.63)	320.8 (12.63)	[Note (1)]
16	400.1 (15.75)	400.1 (15.75)	389.9 (15.35)	389.9 (15.35)	374.7 (14.75)	368.3 (14.50)	[Note (1)]
18	449.3 (17.69)	449.3 (17.69)	438.2 (17.25)	438.2 (17.25)	425.5 (16.75)	425.5 (16.75)	[Note (1)]
20	500.1 (19.69)	500.1 (19.69)	489.0 (19.25)	489.0 (19.25)	482.6 (19.00)	476.3 (18.75)	[Note (1)]
24	603.3 (23.75)	603.3 (23.75)	590.6 (23.25)	590.6 (23.25)	590.6 (23.25)	577.9 (22.75)	[Note (1)]

GENERAL NOTES:

- (a) The inner-ring thickness shall be 2.97 mm to 3.33 mm (0.117 in. to 0.131 in.).
- (b) For sizes NPS 1/2 through NPS 3, the inside diameter tolerance is ± 0.8 mm (± 0.03 in.); for larger sizes, the inside diameter tolerance is ± 1.5 mm (± 0.06 in.). See [Table SW-2.5-1](#) for minimum pipe wall thicknesses that are suitable for use with standard inner rings.
- (c) Refer to [para. SW-2.5](#) for required use of inner rings.

NOTE: (1) There are no Class 400 flanges in NPS 1/2 through NPS 3 1/2 (use Class 600); Class 900 flanges in NPS 1/2 through NPS 2 1/2 or in NPS 3 1/2 (use Class 1500); Class 1500 flanges in NPS 3 1/2; or Class 2500 flanges in NPS 14 and larger.

Table SW-2.1-5 Inside Diameters of Inner Rings for Spiral-Wound Gaskets Used Between ASME B16.47 Series A Flanges

Flange Size (NPS)	Inside Diameter of Inner Ring by Pressure Class, mm (in.)				
	150	300	400	600	900
26	654.1 (25.75)	654.1 (25.75)	660.4 (26.00)	647.7 (25.50)	660.4 (26.00)
28	704.9 (27.75)	704.9 (27.75)	711.2 (28.00)	698.5 (27.50)	711.2 (28.00)
30	755.7 (29.75)	755.7 (29.75)	755.7 (29.75)	755.7 (29.75)	768.4 (30.25)
32	806.5 (31.75)	806.5 (31.75)	812.8 (32.00)	812.8 (32.00)	812.8 (32.00)
34	857.3 (33.75)	857.3 (33.75)	863.6 (34.00)	863.6 (34.00)	863.6 (34.00)
36	908.1 (35.75)	908.1 (35.75)	917.7 (36.13)	917.7 (36.13)	920.8 (36.25)
38	958.9 (37.75)	952.5 (37.50)	952.5 (37.50)	952.5 (37.50)	1 009.7 (39.75)
40	1 009.7 (39.75)	1 003.3 (39.50)	1 000.3 (39.38)	1 009.7 (39.75)	1 060.5 (41.75)
42	1 060.5 (41.75)	1 054.1 (41.50)	1 051.1 (41.38)	1 066.8 (42.00)	1 111.3 (43.75)
44	1 111.3 (43.75)	1 104.9 (43.50)	1 104.9 (43.50)	1 111.3 (43.75)	1 155.7 (45.50)
46	1 162.1 (45.75)	1 152.7 (45.38)	1 168.4 (46.00)	1 162.1 (45.75)	1 219.2 (48.00)
48	1 212.9 (47.75)	1 209.8 (47.63)	1 206.5 (47.50)	1 219.2 (48.00)	1 270.0 (50.00)
50	1 263.7 (49.75)	1 244.6 (49.00)	1 257.3 (49.50)	1 270.0 (50.00)	[Note (1)]
52	1 314.5 (51.75)	1 320.8 (52.00)	1 308.1 (51.50)	1 320.8 (52.00)	[Note (1)]
54	1 358.9 (53.50)	1 352.6 (53.25)	1 352.6 (53.25)	1 378.0 (54.25)	[Note (1)]
56	1 409.7 (55.50)	1 403.4 (55.25)	1 403.4 (55.25)	1 428.8 (56.25)	[Note (1)]
58	1 460.5 (57.50)	1 447.8 (57.00)	1 454.2 (57.25)	1 473.2 (58.00)	[Note (1)]
60	1 511.3 (59.50)	1 524.0 (60.00)	1 517.7 (59.75)	1 530.4 (60.25)	[Note (1)]

GENERAL NOTES:

- (a) The inner-ring thickness shall be 2.97 mm to 3.33 mm (0.117 in. to 0.131 in.).
- (b) The inside diameter tolerance is ± 3.0 mm (± 0.12 in.).
- (c) These inner rings are suitable for use with pipe walls 9.53 mm (0.38 in.) or thicker.
- (d) Refer to [para. SW-2.5](#) for required use of inner rings.

NOTE: (1) There are no Class 900 flanges in NPS 50 and larger.

Table SW-2.1-6 Inside Diameters of Inner Rings for Spiral-Wound Gaskets Used Between ASME B16.47 Series B Flanges

Flange Size (NPS)	Inside Diameter of Inner Ring by Pressure Class, mm (in.)				
	150	300	400	600	900
26	654.1 (25.75)	654.1 (25.75)	654.1 (25.75)	644.7 (25.38)	666.8 (26.25)
28	704.9 (27.75)	704.9 (27.75)	701.8 (27.63)	685.8 (27.00)	717.6 (28.25)
30	755.7 (29.75)	755.7 (29.75)	752.6 (29.63)	752.6 (29.63)	781.1 (30.75)
32	806.5 (31.75)	806.5 (31.75)	800.1 (31.50)	793.8 (31.25)	838.2 (33.00)
34	857.3 (33.75)	857.3 (33.75)	850.9 (33.50)	850.9 (33.50)	895.4 (35.25)
36	908.1 (35.75)	908.1 (35.75)	898.7 (35.38)	901.7 (35.50)	920.8 (36.25)
38	958.9 (37.75)	971.6 (38.25)	952.5 (37.50)	952.5 (37.50)	1 009.7 (39.75)
40	1 009.7 (39.75)	1 022.4 (40.25)	1 000.3 (39.38)	1 009.7 (39.75)	1 060.5 (41.75)
42	1 060.5 (41.75)	1 085.9 (42.75)	1 051.1 (41.38)	1 066.8 (42.00)	1 111.3 (43.75)
44	1 111.3 (43.75)	1 124.0 (44.25)	1 104.9 (43.50)	1 111.3 (43.75)	1 155.7 (45.50)
46	1 162.1 (45.75)	1 178.1 (46.38)	1 168.4 (46.00)	1 162.1 (45.75)	1 219.2 (48.00)
48	1 212.9 (47.75)	1 231.9 (48.50)	1 206.5 (47.50)	1 219.2 (48.00)	1 270.0 (50.00)
50	1 263.7 (49.75)	1 267.0 (49.88)	1 257.3 (49.50)	1 270.0 (50.00)	[Note (1)]
52	1 314.5 (51.75)	1 317.8 (51.88)	1 308.1 (51.50)	1 320.8 (52.00)	[Note (1)]
54	1 365.3 (53.75)	1 365.3 (53.75)	1 352.6 (53.25)	1 378.0 (54.25)	[Note (1)]
56	1 422.4 (56.00)	1 428.8 (56.25)	1 403.4 (55.25)	1 428.8 (56.25)	[Note (1)]
58	1 478.0 (58.19)	1 484.4 (58.44)	1 454.2 (57.25)	1 473.2 (58.00)	[Note (1)]
60	1 535.2 (60.44)	1 557.3 (61.31)	1 517.7 (59.75)	1 530.4 (60.25)	[Note (1)]

GENERAL NOTES:

- (a) The inner-ring thickness shall be 2.97 mm to 3.33 mm (0.117 in. to 0.131 in.).
 (b) The inside diameter tolerance is ± 3.0 mm (± 0.12 in.).
 (c) These inner rings are suitable for use with pipe walls 9.53 mm (0.375 in.) or thicker.
 (d) Refer to [para. SW-2.5](#) for required use of inner rings.

NOTE: (1) There are no Class 900 flanges in NPS 50 and larger.

Table SW-2.5-1 Minimum Pipe Wall Thickness Suitable for Use of Spiral-Wound Gaskets With Inner Rings for ASME B16.5 Flanges

Flange Size (NPS)	Minimum Pipe Wall Thickness by Pressure Class						
	150	300	400	600	900	1500	2500
1/2	Schedule 80						
3/4							
1							
1 1/4	Schedule 40					Schedule 80	
1 1/2							
2							
2 1/2	Schedule 80						
3							
4							
5	Schedule 10S						
6							
8							
10	Schedule 30		Schedule 80			Schedule 80	
12							
14							
16	Schedule 10S		Schedule 30		Schedule 80		
18							
20							
24							

GENERAL NOTES:

- (a) The pipe wall schedules identified represent the minimum recommended pipe wall thickness suitable for use with inner rings for ASME B16.5 flanges. (Reference ASME B36.10M and ASME B36.19M.)
- (b) Gaskets with inner rings should be used only with socket welding, lapped, welding neck, and integral flanges.
- (c) Refer to [para. SW-2.5](#) for required use of inner rings.

Table SW-2.5-2 Maximum Bore of ASME B16.5 Flanges for Use With Spiral-Wound Gaskets

Flange Size (NPS)	Maximum Bore by Pressure Class							
	75	150	300	400	600	900 [Note (1)]	1500 [Note (1)]	2500 [Note (1)]
1/2	No flanges	WN flange only [Note (2)]		No flanges Use Class 600	WN flange only [Note (2)]	No flanges Use Class 1500	WN flange only [Note (2)]	
3/4					SO flange [Note (3)]			
1					WN flange [Note (2)]			
1 1/4					SO flange [Note (3)]			
1 1/2		WN flange, any bore	SO flange [Note (3)] WN flange, any bore	SO flange [Note (3)] WN flange, any bore				
2		WN flange, any bore						
2 1/2		SO flange WN flange, any bore	WN flange with Schedule 10S bore described in ASME B36.19M [includes nozzle [Note (4)] but excludes SO flange]	WN flange with SW bore [includes nozzle [Note (4)] but excludes SO flange]				
3								
4								
6		SO flange WN flange, any bore	WN flange with Schedule 10S bore described in ASME B36.19M [excludes nozzle [Note (4)] and SO flange] [Note (5)]	WN flange with Schedule 80 bore [excludes nozzle [Note (4)] and SO flange] [Note (5)]	No flanges			
8								
10								
12								
14								
16								
18								
20								
24								

GENERAL NOTES:

- (a) This Table shows the maximum bore of flanges for which the spiral-wound gasket dimensions shown in [Table SW-2.1-1](#) are recommended, considering the tolerances involved, possible eccentric installation, and the possibility that the gasket may extend into the assembled flange bore.
- (b) For maximum permissible flange bores for nonmandatory inner rings, see [Table SW-2.5-1](#).
- (c) Abbreviations: SO = slip on and threaded, WN = welding neck, and SW = standard wall.

NOTES:

- (1) Refer to [para. SW-2.5](#) for required use of inner rings. These inner rings may extend into the pipe bore a maximum of 1.5 mm (0.06 in.) under the worst combination of maximum bore, eccentric installation, and additive tolerances.
- (2) In these sizes, the gasket is suitable for a welding neck flange with a standard wall bore, if the gasket and flanges are assembled concentrically. This also applies to a nozzle. It is the user's responsibility to determine if the gasket is satisfactory for a flange of any larger bore.
- (3) Gaskets in these sizes are suitable for slip-on flanges only if the gaskets and flanges are assembled concentrically.
- (4) A nozzle is a long welding neck; the bore equals the flange NPS.
- (5) An NPS 24 gasket is suitable for nozzles.

Table SW-2.5-3 Maximum Bore of ASME B16.47 Series A Flanges for Use With Spiral-Wound Gaskets

Flange Size (NPS)	Maximum Bore by Pressure Class				
	150	300	400	600	900
26	Note (1)	Note (2)	Note (2)	Note (2)	Note (2)
28	Note (1)	Note (2)	Note (2)	Note (2)	Note (2)
30	Note (1)	Note (2)	Note (2)	Note (2)	Note (2)
32	Note (1)	Note (2)	Note (2)	Note (2)	Note (2)
34	Note (1)	Note (2)	Note (2)	Note (2)	Note (2)
36	Note (1)	Note (2)	Note (2)	Note (2)	Note (2)
38	Note (1)	Note (2)	Note (2)	Note (2)	Note (2)
40	Note (1)	Note (2)	Note (2)	Note (2)	Note (2)
42	Note (1)	Note (2)	Note (2)	Note (2)	Note (2)
44	Note (1)	Note (2)	Note (2)	Note (2)	Note (2)
46	Note (1)	Note (2)	Note (2)	Note (2)	Note (2)
48	Note (1)	Note (2)	Note (2)	Note (2)	Note (2)
50	Note (1)	Note (2)	Note (2)	Note (2)	Note (3)
52	Note (1)	Note (2)	Note (2)	Note (2)	Note (3)
56	Note (1)	Note (2)	Note (2)	Note (2)	Note (3)
58	Note (1)	Note (2)	Note (2)	Note (2)	Note (3)
60	Note (1)	Note (2)	Note (2)	Note (2)	Note (3)

GENERAL NOTES:

- (a) This Table shows the maximum bore of flanges for which the spiral-wound gasket dimensions shown in [Table SW-2.1-2](#) are recommended, considering the tolerances involved, the possibility of eccentric installation, and the possibility that the gasket may extend into the assembled flange bore. [Get more FREE standards from Standard Sharing Group and our chats](#)
- (b) Refer to [para. SW-2.5](#) for required use of inner rings.

NOTES:

- (1) Applies only to welding neck flanges with a bore not larger than the inside diameter of a 4.75-mm (0.187-in.) wall pipe. Larger bores must be checked individually.
- (2) Applies only to welding neck flanges with a bore not larger than the inside diameter of a 6.4-mm (0.25-in.) wall pipe, except that NPS 38, Class 300 is not suitable for a bore larger than the inside diameter of a 7.6-mm (0.30-in.) wall pipe. Larger bores must be checked individually.
- (3) There are no Class 900 flanges in NPS 50 and larger.

Table SW-2.5-4 Maximum Bore of ASME B16.47 Series B Flanges for Use With Spiral-Wound Gaskets

Flange Size (NPS)	Maximum Bore by Pressure Class				
	150	300	400	600	900
26	Note (1)	Note (1)	Note (1)	Note (1)	Note (1)
28	Note (1)	Note (1)	Note (1)	Note (1)	Note (1)
30	Note (1)	Note (1)	Note (1)	Note (1)	Note (1)
32	Note (1)	Note (1)	Note (1)	Note (1)	Note (1)
34	Note (1)	Note (1)	Note (1)	Note (1)	Note (1)
36	Note (1)	Note (1)	Note (1)	Note (1)	Note (1)
38	Note (1)	Note (1)	Note (1)	Note (1)	Note (1)
40	Note (1)	Note (1)	Note (1)	Note (1)	Note (1)
44	Note (1)	Note (1)	Note (1)	Note (1)	Note (1)
46	Note (1)	Note (1)	Note (1)	Note (1)	Note (1)
48	Note (1)	Note (1)	Note (1)	Note (1)	Note (1)
50	Note (1)	Note (1)	Note (1)	Note (1)	Note (2)
52	Note (1)	Note (1)	Note (1)	Note (1)	Note (2)
54	Note (1)	Note (1)	Note (1)	Note (1)	Note (2)
56	Note (1)	Note (1)	Note (1)	Note (1)	Note (2)
58	Note (1)	Note (1)	Note (1)	Note (1)	Note (2)
60	Note (1)	Note (1)	Note (1)	Note (1)	Note (2)

GENERAL NOTES:

- (a) This Table shows the maximum bore of flanges for which the spiral-wound gasket dimensions shown in [Table SW-2.1-3](#) are recommended, considering the tolerances involved, the possibility of eccentric installation, and the possibility that the gasket may extend into the assembled flange bore.
- (b) Refer to [para. SW-2.5](#) for required use of inner rings.

NOTES:

- (1) Welding neck and integral flanges having maximum inside diameters as described in ASME B16.47.
- (2) There are no Class 900 flanges in NPS 50 and larger.

Table SW-3-1 Color Coding and Abbreviations for Spiral-Wound Gasket Materials

Material	Abbreviation	Color Code
Metallic Winding Materials		
Carbon steel	CRS	Silver
Type 304 SS	304	Yellow
Type 304 L SS	304 L	No color
Type 309 SS	309	No color
Type 310 SS	310	No color
Type 316 L SS	316 L	Green
Type 317 L SS	317 L	Maroon
Type 321 SS	321	Turquoise
Type 347 SS	347	Blue
Type 430 SS	430	No color
Ni-Cu
Monel 400	MON	Orange
Grade 400
Nickel 200	NI	Red
Titanium	TI	Purple
20Cb-3 alloy	A-20	Black
Ni-Mo
Hastelloy B	HAST B	Brown
Grade B2
Ni-Mo-Cr
Hastelloy C	HAST C	Beige
Grade C-276
Ni-Cr-Fe
Inconel 600	INC 600	Gold
Grade 600
Ni-Cr-Fe-Cb
Inconel 625	INC 625	Gold
Grade 625
Ni-Cr-Fe-Ti
Inconel X-750	INX	No color
Grade X-750
Ni-Fe-Cr
Incoloy 800	IN 800	White
Grade 800
Ni-Fe-Cr-Mo-Cu
Incoloy 825	IN 825	White
Grade 825
Zirconium	ZIRC	No color
All Other Materials	Manufacturer's standard	No color
Nonmetallic Filler Materials		
Polytetrafluoroethylene	PTFE	White stripe
Vermiculite	...	Light blue stripe
Phlogopite (magnesium mica)	...	Light blue stripe
Flexible graphite	FG	Gray stripe
Ceramic	CER	Light green stripe

Table SW-4.1-1 Example Markings for Spiral-Wound Gaskets

Description	Marking
NPS 3, Classes 300 and 600 ASME B16.5 gaskets having a Type 304 metal winding and a flexible graphite filler material	3-300/600—FG (Manufacturer's trademark) ASME B16.20
NPS 36, Class 300 ASME B16.47 Series A gasket having a Type 304 metal winding and a ceramic filler material	36-300—CER ASME B16.47 A (Manufacturer's trademark) ASME B16.20
NPS 12, Class 1500 ASME B16.5 gasket having an Inconel metal winding, PTFE filler material, and an Inconel inner ring	12-1500 INC 600—PTFE INC 600 I.R. (Manufacturer's trademark) ASME B16.20

PART JA

JACKETED GASKETS

JA-1 SIZE AND PRESSURE CLASS

Jacketed gaskets are identified by flange size (NPS), pressure class, and the appropriate flange standard (ASME B16.5 or ASME B16.47).

JA-2 DESIGN

JA-2.1 General

Jacketed gaskets shall be made with a filler material enclosed in a metal jacket.

JA-2.2 Jacket Thickness

The jacket metal thickness shall be a minimum of 0.38 mm (0.015 in.).

JA-2.3 Filler Thickness

The filler thickness shall be a minimum of 1.5 mm (0.06 in.).

JA-2.4 Miscellaneous

Other design details, including the density of the filler, shall be the gasket manufacturer's responsibility.

JA-3 DIMENSIONS AND TOLERANCES

Gasket dimensions and tolerances shall be in accordance with [Figure JA-3-1](#) and [Tables JA-3-1](#) through [JA-3-3](#).

JA-4 MATERIALS

Metal jacket and filler material shall be selected from [Table JA-4-1](#) or as agreed between the purchaser and manufacturer. For recommendations regarding use of jacketed gaskets with ASME B16.5 flanges, see ASME B16.5, para. 5-4.

JA-5 MARKING

JA-5.1 Applied Marking

Jacketed gaskets shall be marked with waterproof ink or equivalent. Where gasket size does not permit such markings, a separate attached marking tag may be used. The lettering height shall be a minimum of 5 mm (0.2 in.). The following information shall be included with the markings:

(a) manufacturer's name or trademark.

(b) flange size (NPS).

(c) pressure class.

(d) jacketed material abbreviation (see [Table JA-4-1](#)), except that the abbreviation may be omitted when soft carbon steel is used.

(e) filler material abbreviation (see [Table JA-4-1](#)).

(f) flange identification. Gaskets intended for ASME B16.47 flanges shall be marked B16.47 A or B16.47 B, as applicable. Gaskets intended for ASME B16.5 flanges need not be so marked. Illustrative marking examples are shown in [Table JA-5.1-1](#).

(g) ASME B16.20 designation.

JA-5.2 Pressure Class

Gaskets suitable for more than one pressure class shall be marked with all applicable classes.

Figure JA-3-1 Jacketed Gasket

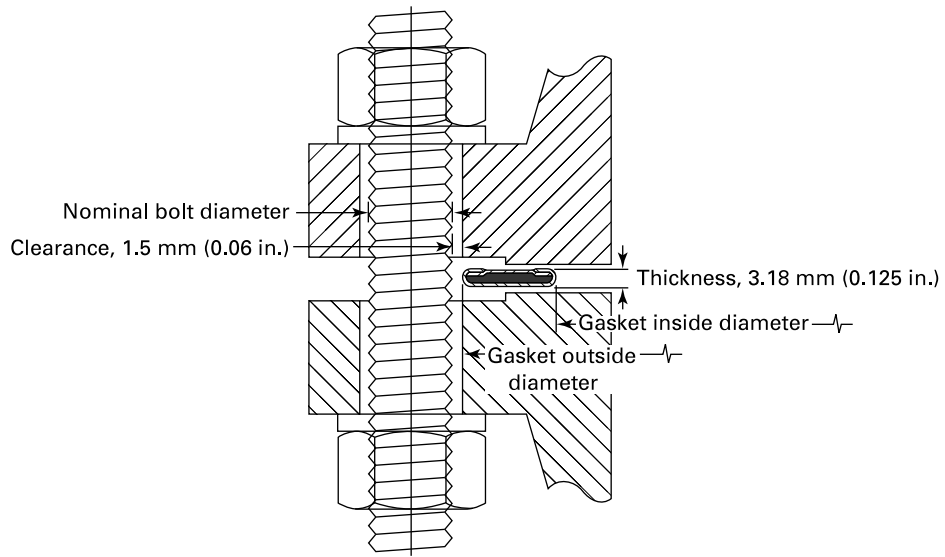

Table JA-3-1 Jacketed Gasket Dimensions for ASME B16.5 Flanges

Flange Size (NPS)	Gasket Inside Diameter, mm (in.) [Note (1)]	Gasket Outside Diameter by Pressure Class, mm (in.) [Note (1)]						
		150	300	400	600	900	1500	2500
1/2	22.4 (0.88)	44.5 (1.75)	50.8 (2.00)	[Note (2)]	50.8 (2.00)	[Note (2)]	60.5 (2.38)	66.8 (2.63)
3/4	28.7 (1.13)	54.1 (2.13)	63.5 (2.50)	[Note (2)]	63.5 (2.50)	[Note (2)]	66.8 (2.63)	73.2 (2.88)
1	38.1 (1.50)	63.5 (2.50)	69.9 (2.75)	[Note (2)]	69.9 (2.75)	[Note (2)]	76.2 (3.00)	82.6 (3.25)
1 1/4	47.8 (1.88)	73.2 (2.88)	79.5 (3.13)	[Note (2)]	79.5 (3.13)	[Note (2)]	85.9 (3.38)	101.6 (4.00)
1 1/2	54.1 (2.13)	82.6 (3.25)	92.2 (3.63)	[Note (2)]	92.2 (3.63)	[Note (2)]	95.3 (3.75)	114.3 (4.50)
2	73.2 (2.88)	101.6 (4.00)	108.0 (4.25)	[Note (2)]	108.0 (4.25)	[Note (2)]	139.7 (5.50)	143.0 (5.63)
2 1/2	85.9 (3.38)	120.7 (4.75)	127.0 (5.00)	[Note (2)]	127.0 (5.00)	[Note (2)]	162.1 (6.38)	165.1 (6.50)
3	108.0 (4.25)	133.4 (5.25)	146.1 (5.75)	[Note (2)]	146.1 (5.75)	165.1 (6.50)	171.5 (6.75)	193.8 (7.63)
4	131.8 (5.19)	171.5 (6.75)	177.8 (7.00)	174.8 (6.88)	190.5 (7.50)	203.2 (8.00)	206.5 (8.13)	231.9 (9.13)
5	152.4 (6.00)	193.8 (7.63)	212.9 (8.38)	209.6 (8.25)	238.3 (9.38)	244.6 (9.63)	251.0 (9.88)	276.4 (10.88)
6	190.5 (7.50)	219.2 (8.63)	247.7 (9.75)	244.6 (9.63)	263.7 (10.38)	285.8 (11.25)	279.4 (11.00)	314.5 (12.38)
8	238.3 (9.38)	276.4 (10.88)	304.8 (12.00)	301.8 (11.88)	317.5 (12.50)	355.6 (14.00)	349.3 (13.75)	384.3 (15.13)
10	285.8 (11.25)	336.6 (13.25)	358.9 (14.13)	355.6 (14.00)	397.0 (15.63)	431.8 (17.00)	431.8 (17.00)	473.2 (18.63)
12	342.9 (13.50)	406.4 (16.00)	419.1 (16.50)	416.1 (16.38)	454.2 (17.88)	495.3 (19.50)	517.7 (20.38)	546.1 (21.50)
14	374.7 (14.75)	447.8 (17.63)	482.6 (19.00)	479.6 (18.88)	489.0 (19.25)	517.7 (20.38)	574.8 (22.63)	[Note (2)]
16	425.5 (16.75)	511.3 (20.13)	536.7 (21.13)	533.4 (21.00)	562.1 (22.13)	571.5 (22.50)	638.3 (25.13)	[Note (2)]
18	489.0 (19.25)	546.1 (21.50)	593.9 (23.38)	590.6 (23.25)	609.6 (24.00)	635.0 (25.00)	701.8 (27.63)	[Note (2)]
20	533.4 (21.00)	603.3 (23.75)	651.0 (25.63)	644.7 (25.38)	679.5 (26.75)	695.5 (27.38)	752.6 (29.63)	[Note (2)]
24	641.4 (25.25)	714.5 (28.13)	771.7 (30.38)	765.3 (30.13)	787.4 (31.00)	835.2 (32.88)	898.7 (35.38)	[Note (2)]

GENERAL NOTES:

- (a) For reference, see [Figure JA-3-1](#).
 (b) The gasket thickness tolerance is +0.8 mm, -0.0 mm (+0.03 in., -0.000 in.).

NOTES:

- (1) For gaskets NPS 1/2 through NPS 24, the outside and inside diameter tolerances are +1.5 mm, -0.0 mm (+0.06 in., -0.000 in.).
 (2) There are no Class 400 flanges in NPS 1/2 through NPS 3 (use Class 600), Class 900 flanges in NPS 1/2 through NPS 2 1/2 (use Class 1500), or Class 2500 flanges in NPS 14 and larger.

Table JA-3-2 Jacketed Gasket Dimensions for ASME B16.47 Series A Flanges

Flange Size (NPS)	Gasket Inside Diameter, mm (in.) [Note (1)]	Gasket Outside Diameter by Pressure Class, mm (in.) [Note (1)]				
		150	300	400	600	900
26	673.1 (26.50)	771.7 (30.38)	831.9 (32.75)	828.8 (32.63)	863.6 (34.00)	879.6 (34.63)
28	723.9 (28.50)	828.8 (32.63)	895.4 (35.25)	889.0 (35.00)	911.4 (35.88)	943.1 (37.13)
30	774.7 (30.50)	879.6 (34.63)	949.5 (37.38)	943.1 (37.13)	968.5 (38.13)	1 006.6 (39.63)
32	825.5 (32.50)	936.8 (36.88)	1 003.3 (39.50)	1 000.3 (39.38)	1 019.3 (40.13)	1 070.1 (42.13)
34	876.3 (34.50)	987.6 (38.88)	1 054.1 (41.50)	1 051.1 (41.38)	1 070.1 (42.13)	1 133.6 (44.63)
36	927.1 (36.50)	1 044.7 (41.13)	1 114.6 (43.88)	1 114.6 (43.88)	1 127.3 (44.38)	1 197.1 (47.13)
38	977.9 (38.50)	1 108.2 (43.63)	1 051.1 (41.38)	1 070.1 (42.13)	1 101.9 (43.38)	1 197.1 (47.13)
40	1 028.7 (40.50)	1 159.0 (45.63)	1 111.3 (43.75)	1 124.0 (44.25)	1 152.7 (45.38)	1 247.9 (49.13)
42	1 079.5 (42.50)	1 216.2 (47.88)	1 162.1 (45.75)	1 174.8 (46.25)	1 216.2 (47.88)	1 298.7 (51.13)
44	1 130.3 (44.50)	1 273.3 (50.13)	1 216.2 (47.88)	1 228.9 (48.38)	1 267.0 (49.88)	1 365.3 (53.75)
46	1 181.1 (46.50)	1 324.1 (52.13)	1 270.0 (50.00)	1 286.0 (50.63)	1 324.1 (52.13)	1 432.1 (56.38)
48	1 231.9 (48.50)	1 381.3 (54.38)	1 320.8 (52.00)	1 343.2 (52.88)	1 387.6 (54.63)	1 482.9 (58.38)
50	1 282.7 (50.50)	1 432.1 (56.38)	1 374.9 (54.13)	1 400.3 (55.13)	1 444.8 (56.88)	[Note (2)]
52	1 333.5 (52.50)	1 489.2 (58.63)	1 425.7 (56.13)	1 451.1 (57.13)	1 495.6 (58.88)	[Note (2)]
54	1 384.3 (54.50)	1 546.4 (60.88)	1 489.2 (58.63)	1 514.6 (59.63)	1 552.7 (61.13)	[Note (2)]
56	1 435.1 (56.50)	1 603.5 (63.13)	1 540.0 (60.63)	1 565.4 (61.63)	1 603.5 (63.13)	[Note (2)]
58	1 485.9 (58.50)	1 660.7 (65.38)	1 590.8 (62.63)	1 616.2 (63.63)	1 660.7 (65.38)	[Note (2)]
60	1 536.7 (60.50)	1 711.5 (67.38)	1 641.6 (64.63)	1 679.7 (66.13)	1 730.5 (68.13)	[Note (2)]

GENERAL NOTES:

- (a) For reference, see [Figure JA-3-1](#).
(b) The gasket thickness tolerance is +0.8 mm, -0.0 mm (+0.03 in., -0.000 in.).

NOTES:

- (1) For gaskets NPS 26 through NPS 60, the outside diameter and inside diameter tolerances are +3.3 mm, -0.0 mm (+0.13 in., -0.000 in.).
(2) There are no Class 900 flanges in NPS 50 and larger.

Table JA-3-3 Jacketed Gasket Dimensions for ASME B16.47 Series B Flanges

Flange Size (NPS)	Gasket Inside Diameter, mm (in.) [Note (1)]	Gasket Outside Diameter by Pressure Class, mm (in.) [Note (1)]				
		150	300	400	600	900
26	673.1 (26.50)	722.4 (28.44)	768.4 (30.25)	743.0 (29.25)	762.0 (30.00)	835.2 (32.88)
28	723.9 (28.50)	773.2 (30.44)	822.5 (32.38)	797.1 (31.38)	816.1 (32.13)	898.7 (35.38)
30	774.7 (30.50)	824.0 (32.44)	882.7 (34.75)	854.2 (33.63)	876.3 (34.50)	955.8 (37.63)
32	825.5 (32.50)	877.8 (34.56)	936.8 (36.88)	908.1 (35.75)	930.4 (36.63)	1 013.0 (39.88)
34	876.3 (34.50)	931.9 (36.69)	990.6 (39.00)	958.9 (37.75)	993.9 (39.13)	1 070.1 (42.13)
36	927.1 (36.50)	984.3 (38.75)	1 044.7 (41.13)	1 019.3 (40.13)	1 044.7 (41.13)	1 120.9 (44.13)
38	977.9 (38.50)	1 041.4 (41.00)	1 095.5 (43.13)	1 070.1 (42.13)	1 101.9 (43.38)	1 197.1 (47.13)
40	1 028.7 (40.50)	1 092.2 (43.00)	1 146.3 (45.13)	1 124.0 (44.25)	1 152.7 (45.38)	1 247.9 (49.13)
42	1 079.5 (42.50)	1 143.0 (45.00)	1 197.1 (47.13)	1 174.8 (46.25)	1 216.2 (47.88)	1 298.7 (51.13)
44	1 130.3 (44.50)	1 193.8 (47.00)	1 247.9 (49.13)	1 228.9 (48.38)	1 267.0 (49.88)	1 365.3 (53.75)
46	1 181.1 (46.50)	1 252.5 (49.31)	1 314.5 (51.75)	1 286.0 (50.63)	1 324.1 (52.13)	1 432.1 (56.38)
48	1 231.9 (48.50)	1 303.3 (51.31)	1 365.3 (53.75)	1 343.2 (52.88)	1 387.6 (54.63)	1 482.9 (58.38)
50	1 282.7 (50.50)	1 354.1 (53.31)	1 416.1 (55.75)	1 400.3 (55.13)	1 444.8 (56.88)	[Note (2)]
52	1 333.5 (52.50)	1 404.9 (55.31)	1 466.9 (57.75)	1 451.1 (57.13)	1 495.6 (58.88)	[Note (2)]
54	1 384.3 (54.50)	1 460.5 (57.50)	1 527.3 (60.13)	1 514.6 (59.63)	1 552.7 (61.13)	[Note (2)]
56	1 435.1 (56.50)	1 511.3 (59.50)	1 590.8 (62.63)	1 565.4 (61.63)	1 603.5 (63.13)	[Note (2)]
58	1 485.9 (58.50)	1 576.3 (62.06)	1 652.5 (65.06)	1 616.2 (63.63)	1 660.7 (65.38)	[Note (2)]
60	1 536.7 (60.50)	1 627.1 (64.06)	1 703.3 (67.06)	1 679.7 (66.13)	1 730.5 (68.13)	[Note (2)]

GENERAL NOTES: [Get more FREE standards from Standard Sharing Group and our chats](#)

(a) For reference, see [Figure JA-3-1](#).

(b) The gasket thickness tolerance is +0.8 mm, -0.0 mm (+0.03 in., -0.000 in.).

NOTES:

(1) For gaskets NPS 26 through NPS 60, the outside diameter and inside diameter tolerances are +3.3 mm, -0.0 mm (+0.13 in., -0.000 in.).

(2) There are no Class 900 flanges in NPS 50 and larger.

Table JA-4-1 Abbreviations for Identifying Materials for Jacketed Gaskets

Material	Abbreviation
Metals	
Aluminum (Al)	AL
Carbon steel (CRS)	CS
Copper (Cu)	CU
Hastelloy B [Ni-Mo (grade B2)]	HAST B
Hastelloy C [Ni-Mo-Cr (grade C-276)]	HAST C
Inconel 600 [Ni-Cr-Fe (grade 600)]	INC 600
Inconel 625 [Ni-Cr-Fe-Cb (grade 625)]	INC 625
Incoloy 800 [Ni-Fe-Cr (grade 800)]	IN 800
Inconel X-750 [Ni-Cr-Fe-Ti (grade X-750)]	INX
Monel [Ni-Cu (grade 400)]	MON
Nickel (Nickel 200)	NI
Soft iron	Soft iron
Stainless steels (Ni-Cr)	3-digit
Tantalum (Ta)	TANT
Titanium (Ti)	TI
Fillers	
Asbestos	ASB
Ceramic	CER
Flexible graphite	FG
Polytetrafluoroethylene	PTFE

Table JA-5.1-1 Example Markings for Jacketed Gaskets

Description	Marking
NPS 2½, Class 150 ASME B16.5 gasket having a Type 304 metal jacket and a flexible graphite filler material	2½-150—304/FG (Manufacturer's trademark) ASME B16.20
NPS 30, Class 300 ASME B16.47 Series B gasket having a carbon-steel jacket and a ceramic filler material	30-300—CS/CER ASME B16.47 B (Manufacturer's trademark) ASME B16.20

PART GM

GROOVED METAL GASKETS WITH COVERING LAYERS

GM-1 SIZE AND CLASS

Grooved metal gaskets with covering layers having a centering ring are identified by flange size (NPS), pressure class, and the appropriate flange standard (ASME B16.5 or ASME B16.47).

GM-2 DIMENSIONS AND TOLERANCES

GM-2.1 General

Dimensions and tolerances for grooved metal gaskets with covering layers and centering rings shall be as specified in this Part and in accordance with [Figure GM-2.1-1](#) and [Tables GM-2.1-1](#) through [GM-2.1-3](#).

GM-2.2 Construction

Grooved metal gaskets with covering layers shall be constructed as a concentrically grooved metal core (sealing element) with a centering ring. The grooved metal portion of the finished gasket shall be faced with a covering layer on both sealing surfaces that is 0.46 mm to 0.56 mm (0.018 in. to 0.022 in.) thick. The thickness of the metal core of the gasket shall be 2.97 mm to 3.33 mm (0.117 in. to 0.131 in.). The thickness on any single gasket shall be uniform within a maximum tolerance range of 0.13 mm (0.005 in.).

GM-2.3 Welding

Welding is permitted only in NPS 14 and larger gaskets. Welding shall be subject to the following:

- (a) Full penetration welds shall be used.
- (b) Where only two welds are used, the minimum weld spacing shall be 152 mm (6 in.). Where more than two welds are required, minimum weld spacing shall be 609 mm (24 in.). Weld spacing shall be measured along the inside circumference of the metal core. When material availability precludes this weld spacing, then additional welding, as agreed by the purchaser and manufacturer, is permitted.
- (c) The grooves shall be machined into the core after welding.
- (d) In welded areas, the groove, peak profile, and base metal shall be uniform in spacing, thickness, and height with the adjacent metal core.

(e) When specified by the purchaser, weld inspection methods, such as ultrasonic or radiographic, along with acceptance criteria, shall be established.

GM-2.4 Centering Ring

A centering ring is required and used to help position the gasket within the flange bolt circle. Unless otherwise specified by the purchaser, the centering ring shall have a nominal thickness of 1.6 mm (0.06 in.) and shall be suitably attached to the grooved metal core using an integral (one-piece or welded) or nonintegral attachment method. The thickness of the centering ring shall not exceed the thickness of the core.

GM-3 MATERIALS

GM-3.1 Covering

Covering material shall be selected from [Table GM-3.1-1](#).

GM-3.2 Core

Core material shall be selected from [Table GM-3.1-1](#).

GM-3.3 Centering Ring

When carbon steel centering rings are selected, they shall be painted, metal plated, or otherwise coated to inhibit atmospheric corrosion.

GM-4 MARKING

GM-4.1 General

The centering ring shall be permanently marked. The lettering height shall be a minimum of 2.5 mm (0.1 in.), except where space requirements dictate use of a smaller size character. The following information shall be included:

- (a) manufacturer's name or trademark.
- (b) flange size (NPS).
- (c) pressure class.
- (d) metal core abbreviation ([Table GM-3.1-1](#)), except that the abbreviation may be omitted when Type 304 stainless steel is used.
- (e) covering material abbreviation ([Table GM-3.1-1](#)).

(17)

Figure GM-2.1-1 Grooved Metal Gasket With Covering Layers

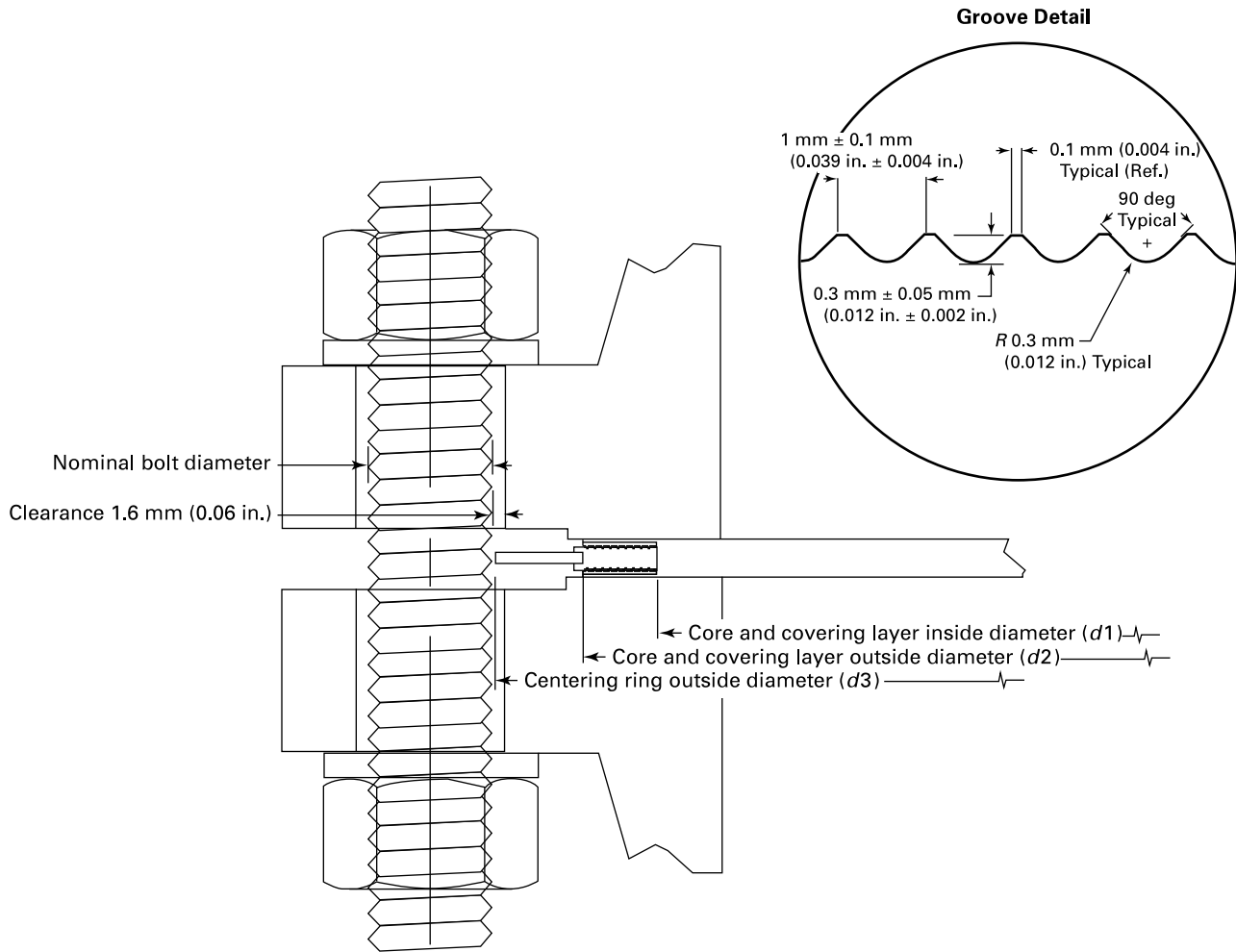

(f) centering-ring metal abbreviation (Table GM-3.1-1).

(g) flange identification. Gaskets used for ASME B16.47 flanges shall be marked B16.47 A or B16.47 B, as applicable. Illustrative marking examples are shown in Table GM-4.1-1. See also Figure GM-4.1-1.

(h) ASME B16.20 designation.

GM-4.2 Pressure Class

Gaskets suitable for more than one pressure class shall be marked with all applicable classes, as shown in Table GM-4.1-1.

GM-4.3 Color Coding

Gaskets shall be marked with a color code that identifies the metal core and facing materials. A continuous color around the outer edge of the centering ring shall identify the core metal. The color identifying the facing material for NPS 3 and larger shall have a minimum of four stripes equally spaced on the outer edge of the centering ring. Smaller size gaskets shall have a minimum of two stripes 180 deg apart. The colors shall conform to those listed in Table GM-3.1-1. Special material not listed in Table GM-3.1-1 shall not be color coded. Users shall refer to the guide ring marking for material.

Table GM-2.1-1 Dimensions for Grooved Metal Gaskets With Covering Layers Used With ASME B16.5 Flanges

Flange Size (NPS)	Grooved Metal Core, mm (in.)		Centering-Ring Outside Diameter, d_3 , mm (in.) [Note (3)]						
	Inside Diameter, d_1 [Note (1)]	Outside Diameter, d_2 [Note (2)]	Pressure Class						
			150	300	400	600	900	1500	2500
1/2	23.1 (0.91)	33.3 (1.31)	47.8 (1.88)	54.1 (2.13)	Note (4)	54.1 (2.13)	Note (4)	63.5 (2.50)	69.9 (2.75)
3/4	28.7 (1.13)	39.6 (1.56)	57.2 (2.25)	66.8 (2.63)	Note (4)	66.8 (2.63)	Note (4)	69.9 (2.75)	76.2 (3.00)
1	36.6 (1.44)	47.5 (1.87)	66.8 (2.63)	73.2 (2.88)	Note (4)	73.2 (2.88)	Note (4)	79.5 (3.13)	85.9 (3.38)
1 1/4	44.5 (1.75)	60.2 (2.37)	76.2 (3.00)	82.6 (3.25)	Note (4)	82.6 (3.25)	Note (4)	88.9 (3.50)	104.9 (4.13)
1 1/2	52.3 (2.06)	69.9 (2.75)	85.9 (3.38)	95.3 (3.75)	Note (4)	95.3 (3.75)	Note (4)	98.6 (3.88)	117.6 (4.63)
2	69.9 (2.75)	88.9 (3.50)	104.9 (4.13)	111.3 (4.38)	Note (4)	111.3 (4.38)	Note (4)	143.0 (5.63)	146.1 (5.75)
2 1/2	82.6 (3.25)	101.6 (4.00)	124.0 (4.88)	130.3 (5.13)	Note (4)	130.3 (5.13)	Note (4)	165.1 (6.50)	168.4 (6.63)
3	98.3 (3.87)	123.7 (4.87)	136.7 (5.38)	149.4 (5.88)	Note (4)	149.4 (5.88)	168.4 (6.63)	174.8 (6.88)	196.9 (7.75)
4	123.7 (4.87)	153.9 (6.06)	174.8 (6.88)	181.1 (7.13)	177.8 (7.00)	193.8 (7.63)	206.5 (8.13)	209.6 (8.25)	235.0 (9.25)
5	150.9 (5.94)	182.6 (7.19)	196.9 (7.75)	215.9 (8.50)	212.9 (8.38)	241.3 (9.50)	247.7 (9.75)	254.0 (10.00)	279.4 (11.00)
6	177.8 (7.00)	212.6 (8.37)	222.3 (8.75)	251.0 (9.88)	247.7 (9.75)	266.7 (10.50)	289.1 (11.38)	282.7 (11.13)	317.5 (12.50)
8	228.6 (9.00)	266.7 (10.50)	279.4 (11.00)	308.1 (12.13)	304.8 (12.00)	320.8 (12.63)	358.9 (14.13)	352.6 (13.88)	387.4 (15.25)
10	282.7 (11.13)	320.8 (12.63)	339.9 (13.38)	362.0 (14.25)	358.9 (14.13)	400.1 (15.75)	435.1 (17.13)	435.1 (17.13)	476.3 (18.75)
12	339.6 (13.37)	377.7 (14.87)	409.7 (16.13)	422.4 (16.63)	419.1 (16.50)	457.2 (18.00)	498.6 (19.63)	520.7 (20.50)	549.4 (21.63)
14	371.6 (14.63)	409.7 (16.13)	450.9 (17.75)	485.9 (19.13)	482.6 (19.00)	492.3 (19.38)	520.7 (20.50)	577.9 (22.75)	Note (4)
16	422.4 (16.63)	466.6 (18.37)	514.4 (20.25)	539.8 (21.25)	536.7 (21.13)	565.2 (22.25)	574.8 (22.63)	641.4 (25.25)	Note (4)
18	479.3 (18.87)	530.1 (20.87)	549.4 (21.63)	596.9 (23.50)	593.9 (23.38)	612.9 (24.13)	638.3 (25.13)	704.9 (27.75)	Note (4)
20	530.1 (20.87)	580.9 (22.87)	606.6 (23.88)	654.1 (25.75)	647.7 (25.50)	682.8 (26.88)	698.5 (27.50)	755.7 (29.75)	Note (4)
24	631.7 (24.87)	682.5 (26.87)	717.6 (28.25)	774.7 (30.50)	768.4 (30.25)	790.7 (31.13)	838.2 (33.00)	901.7 (35.50)	Note (4)

GENERAL NOTE: For reference, see [Figure GM-2.1-1](#).

NOTES:

- (1) The gasket inside diameter, d_1 , tolerance is ± 0.8 mm (± 0.03 in.).
- (2) The gasket outside diameter, d_2 , tolerance is ± 0.8 mm (± 0.03 in.).
- (3) The centering-ring outside diameter, d_3 , tolerance is ± 0.8 mm (± 0.03 in.).
- (4) There are no Class 400 flanges in NPS 1/2 through NPS 3 (use Class 600), Class 900 flanges in NPS 1/2 through NPS 2 1/2 (use Class 1500), or Class 2500 flanges in NPS 14 and larger.

Table GM-2.1-2 Dimensions for Grooved Metal Gaskets With Covering Layers Used With ASME B16.47 Series A Flanges

SI Units, mm																
Flange Size (NPS)	Class 150			Class 300			Class 400			Class 600			Class 900			
	Grooved Core		Centering-Ring Outside Diameter, d3 [Note (3)]	Grooved Core		Centering-Ring Outside Diameter, d3 [Note (3)]	Grooved Core		Centering-Ring Outside Diameter, d3 [Note (3)]	Grooved Core		Centering-Ring Outside Diameter, d3 [Note (3)]	Grooved Core		Centering-Ring Outside Diameter, d3 [Note (3)]	
	Inside Diameter, d1 [Note (1)]	Outside Diameter, d2 [Note (2)]		Inside Diameter, d1 [Note (1)]	Outside Diameter, d2 [Note (2)]		Inside Diameter, d1 [Note (1)]	Outside Diameter, d2 [Note (2)]		Inside Diameter, d1 [Note (1)]	Outside Diameter, d2 [Note (2)]		Inside Diameter, d1 [Note (1)]	Outside Diameter, d2 [Note (2)]		
	26	673.1	704.9	774.7	685.8	736.6	835.2	685.8	736.6	831.9	685.8	736.6	866.9	685.8	736.6	882.7
28	723.9	755.7	831.9	736.6	787.4	898.7	736.6	787.4	892.3	736.6	787.4	914.4	736.6	787.4	946.2	
30	774.7	806.5	882.7	793.8	844.6	952.5	793.8	844.6	946.2	793.8	844.6	971.6	793.8	844.6	1 009.7	
32	825.5	860.6	939.8	850.9	901.7	1 006.6	850.9	901.7	1 003.3	850.9	901.7	1 022.4	850.9	901.7	1 073.2	
34	876.3	911.4	990.6	901.7	952.5	1 057.4	901.7	952.5	1 054.1	901.7	952.5	1 073.2	901.7	952.5	1 136.7	
36	927.1	968.5	1 047.8	955.8	1 006.6	1 117.6	955.8	1 006.6	1 117.6	955.8	1 006.6	1 130.3	958.9	1 009.7	1 200.2	
38	977.9	1 019.3	1 111.3	977.9	1 016.0	1 054.1	971.6	1 022.4	1 073.2	990.6	1 041.4	1 104.9	1 035.1	1 085.9	1 200.2	
40	1 028.7	1 070.1	1 162.1	1 022.4	1 070.1	1 114.6	1 025.7	1 076.5	1 127.3	1 047.8	1 098.6	1 155.7	1 098.6	1 149.4	1 251.0	
42	1 079.5	1 124.0	1 219.2	1 073.2	1 120.9	1 165.4	1 076.5	1 127.3	1 178.1	1 104.9	1 155.7	1 219.2	1 149.4	1 200.2	1 301.8	
44	1 130.3	1 178.1	1 276.4	1 130.3	1 181.1	1 219.2	1 130.3	1 181.1	1 231.9	1 162.1	1 212.9	1 270.0	1 206.5	1 257.3	1 368.6	
46	1 181.1	1 228.9	1 327.2	1 178.1	1 228.9	1 273.3	1 193.8	1 244.6	1 289.1	1 212.9	1 263.7	1 327.2	1 270.0	1 320.8	1 435.1	
48	1 231.9	1 279.7	1 384.3	1 235.2	1 286.0	1 324.1	1 244.6	1 295.4	1 346.2	1 270.0	1 320.8	1 390.7	1 320.8	1 371.6	1 485.9	
50	1 282.7	1 333.5	1 435.1	1 295.4	1 346.2	1 378.0	1 295.4	1 346.2	1 403.4	1 320.8	1 371.6	1 447.8	Note (4)	Note (4)	Note (4)	
52	1 333.5	1 384.3	1 492.3	1 346.2	1 397.0	1 428.8	1 346.2	1 397.0	1 454.2	1 371.6	1 422.4	1 498.6	Note (4)	Note (4)	Note (4)	
54	1 384.3	1 435.1	1 549.4	1 403.4	1 454.2	1 492.3	1 403.4	1 454.2	1 517.7	1 428.8	1 479.6	1 555.8	Note (4)	Note (4)	Note (4)	
56	1 435.1	1 485.9	1 606.6	1 454.2	1 505.0	1 543.1	1 454.2	1 505.0	1 568.5	1 479.6	1 530.4	1 612.9	Note (4)	Note (4)	Note (4)	
58	1 485.9	1 536.7	1 663.7	1 511.3	1 562.1	1 593.9	1 505.0	1 555.8	1 619.3	1 536.7	1 587.5	1 663.7	Note (4)	Note (4)	Note (4)	
60	1 536.7	1 587.5	1 714.5	1 562.1	1 612.9	1 644.7	1 568.5	1 619.3	1 682.8	1 593.9	1 644.7	1 733.6	Note (4)	Note (4)	Note (4)	
U.S. Customary Units, in.																
Flange Size (NPS)	Class 150			Class 300			Class 400			Class 600			Class 900			
	Grooved Core		Centering-Ring Outside Diameter, d3 [Note (3)]	Grooved Core		Centering-Ring Outside Diameter, d3 [Note (3)]	Grooved Core		Centering-Ring Outside Diameter, d3 [Note (3)]	Grooved Core		Centering-Ring Outside Diameter, d3 [Note (3)]	Grooved Core		Centering-Ring Outside Diameter, d3 [Note (3)]	
	Inside Diameter, d1 [Note (1)]	Outside Diameter, d2 [Note (2)]		Inside Diameter, d1 [Note (1)]	Outside Diameter, d2 [Note (2)]		Inside Diameter, d1 [Note (1)]	Outside Diameter, d2 [Note (2)]		Inside Diameter, d1 [Note (1)]	Outside Diameter, d2 [Note (2)]		Inside Diameter, d1 [Note (1)]	Outside Diameter, d2 [Note (2)]		
	26	26.50	27.75	30.50	27.00	29.00	32.88	27.00	29.00	32.75	27.00	29.00	34.13	27.00	29.00	34.75
28	28.50	29.75	32.75	29.00	31.00	35.38	29.00	31.00	35.13	29.00	31.00	36.00	29.00	31.00	37.25	
30	30.50	31.75	34.75	31.25	33.25	37.50	31.25	33.25	37.25	31.25	33.25	38.25	31.25	33.25	39.75	
32	32.50	33.88	37.00	33.50	35.50	39.63	33.50	35.50	39.50	33.50	35.50	40.25	33.50	35.50	42.25	
34	34.50	35.88	39.00	35.50	37.50	41.63	35.50	37.50	41.50	35.50	37.50	42.25	35.50	37.50	44.75	
36	36.50	38.13	41.25	37.63	39.63	44.00	37.63	39.63	44.00	37.63	39.63	44.50	37.75	39.75	47.25	

42

ASME B16.20-2017

Table GM-2.1-2 Dimensions for Grooved Metal Gaskets With Covering Layers Used With ASME B16.47 Series A Flanges (Cont'd)

U.S. Customary Units, in.																
Flange Size (NPS)	Class 150			Class 300			Class 400			Class 600			Class 900			
	Grooved Core		Centering- Ring Outside Diameter, <i>d</i> 3 [Note (3)]	Grooved Core		Centering- Ring Outside Diameter, <i>d</i> 3 [Note (3)]	Grooved Core		Centering- Ring Outside Diameter, <i>d</i> 3 [Note (3)]	Grooved Core		Centering- Ring Outside Diameter, <i>d</i> 3 [Note (3)]	Grooved Core		Centering- Ring Outside Diameter, <i>d</i> 3 [Note (3)]	
	Inside Diameter, <i>d</i> 1	Outside Diameter, <i>d</i> 2		Inside Diameter, <i>d</i> 1	Outside Diameter, <i>d</i> 2		Inside Diameter, <i>d</i> 1	Outside Diameter, <i>d</i> 2		Inside Diameter, <i>d</i> 1	Outside Diameter, <i>d</i> 2		Inside Diameter, <i>d</i> 1	Outside Diameter, <i>d</i> 2		
	[Note (1)]	[Note (2)]	[Note (1)]	[Note (2)]	[Note (1)]	[Note (2)]	[Note (1)]	[Note (2)]	[Note (1)]	[Note (2)]	[Note (1)]	[Note (2)]	[Note (1)]	[Note (2)]		
38	38.50	40.13	43.75	38.50	40.00	41.50	38.25	40.25	42.25	39.00	41.00	43.50	40.75	42.75	47.25	
40	40.50	42.13	45.75	40.25	42.13	43.88	40.38	42.38	44.38	41.25	43.25	45.50	43.25	45.25	49.25	
42	42.50	44.25	48.00	42.25	44.13	45.88	42.38	44.38	46.38	43.50	45.50	48.00	45.25	47.25	51.25	
44	44.50	46.38	50.25	44.50	46.50	48.00	44.50	46.50	48.50	45.75	47.75	50.00	47.50	49.50	53.88	
46	46.50	48.38	52.25	46.38	48.38	50.13	47.00	49.00	50.75	47.75	49.75	52.25	50.00	52.00	56.50	
48	48.50	50.38	54.50	48.63	50.63	52.13	49.00	51.00	53.00	50.00	52.00	54.75	52.00	54.00	58.50	
50	50.50	52.50	56.50	51.00	53.00	54.25	51.00	53.00	55.25	52.00	54.00	57.00	Note (4)	Note (4)	Note (4)	
52	52.50	54.50	58.75	53.00	55.00	56.25	53.00	55.00	57.25	54.00	56.00	59.00	Note (4)	Note (4)	Note (4)	
54	54.50	56.50	61.00	55.25	57.25	58.75	55.25	57.25	59.75	56.25	58.25	61.25	Note (4)	Note (4)	Note (4)	
56	56.50	58.50	63.25	57.25	59.25	60.75	57.25	59.25	61.75	58.25	60.25	63.50	Note (4)	Note (4)	Note (4)	
58	58.50	60.50	65.50	59.50	61.50	62.75	59.25	61.25	63.75	60.50	62.50	65.50	Note (4)	Note (4)	Note (4)	
60	60.50	62.50	67.50	61.50	63.50	64.75	61.75	63.75	66.25	62.75	64.75	68.25	Note (4)	Note (4)	Note (4)	

GENERAL NOTE: For reference, see [Figure GM-2.1-1](#).

NOTES:

- (1) The gasket inside diameter, *d*1, tolerance for NPS 26 through NPS 34 is ±0.8 mm (±0.03 in.), and the tolerance for NPS 36 through NPS 60 is ±1.5 mm (±0.06 in.).
- (2) The gasket outside diameter, *d*2, tolerance for NPS 26 through NPS 60 is ±1.5 mm (±0.06 in.).
- (3) The centering-ring outside diameter, *d*3, tolerance is ±0.8 mm (±0.03 in.).
- (4) There are no Class 900 flanges in NPS 50 and larger.

Table GM-2.1-3 Dimensions for Grooved Metal Gaskets With Covering Layers Used With ASME B16.47 Series B Flanges

SI Units, mm															
Flange Size (NPS)	Class 150			Class 300			Class 400			Class 600			Class 900		
	Grooved Core		Centering-Ring Outside Diameter, d3 [Note (3)]	Grooved Core		Centering-Ring Outside Diameter, d3 [Note (3)]	Grooved Core		Centering-Ring Outside Diameter, d3 [Note (3)]	Grooved Core		Centering-Ring Outside Diameter, d3 [Note (3)]	Grooved Core		Centering-Ring Outside Diameter, d3 [Note (3)]
	Inside Diameter, d1 [Note (1)]	Outside Diameter, d2 [Note (2)]		Inside Diameter, d1 [Note (1)]	Outside Diameter, d2 [Note (2)]		Inside Diameter, d1 [Note (1)]	Outside Diameter, d2 [Note (2)]		Inside Diameter, d1 [Note (1)]	Outside Diameter, d2 [Note (2)]		Inside Diameter, d1 [Note (1)]	Outside Diameter, d2 [Note (2)]	
	26	673.1	698.5	725.4	673.1	711.2	771.7	666.8	698.5	746.3	663.7	714.5	765.3	692.2	749.3
28	723.9	749.3	776.2	723.9	762.0	825.5	714.5	749.3	800.1	704.9	755.7	819.2	743.0	800.1	901.7
30	774.7	800.1	827.0	774.7	812.8	886.0	765.3	806.5	857.3	778.0	828.8	879.6	806.5	857.3	958.9
32	825.5	850.9	881.1	825.5	863.6	939.8	812.8	860.6	911.4	831.9	882.7	933.5	863.6	914.4	1 016.0
34	876.3	908.1	935.0	876.3	914.4	993.9	866.9	911.4	962.2	889.0	939.8	997.0	920.8	971.6	1 073.2
36	927.1	958.9	987.6	927.1	965.2	1 047.8	917.7	965.2	1 022.4	939.8	990.6	1 047.8	946.2	997.0	1 124.0
38	974.9	1 009.7	1 044.7	1 009.7	1 047.8	1 098.6	971.6	1 022.4	1 073.2	990.6	1 041.4	1 104.9	1 035.1	1 085.9	1 200.2
40	1 022.4	1 063.8	1 095.5	1 060.5	1 098.6	1 149.4	1 025.7	1 076.5	1 127.3	1 047.8	1 098.6	1 155.7	1 098.6	1 149.4	1 251.0
42	1 079.5	1 114.6	1 146.3	1 111.3	1 149.4	1 200.2	1 076.5	1 127.3	1 178.1	1 104.9	1 155.7	1 219.2	1 149.4	1 200.2	1 301.8
44	1 124.0	1 165.4	1 197.1	1 162.1	1 200.2	1 251.0	1 130.3	1 181.1	1 231.9	1 162.1	1 212.9	1 270.0	1 206.5	1 257.3	1 368.6
46	1 181.1	1 224.0	1 255.8	1 216.2	1 254.3	1 317.8	1 193.8	1 244.6	1 289.1	1 212.9	1 263.7	1 327.2	1 270.0	1 320.8	1 435.1
48	1 231.9	1 270.0	1 306.6	1 263.7	1 311.4	1 368.6	1 244.6	1 295.4	1 346.2	1 270.0	1 320.8	1 390.7	1 320.8	1 371.6	1 485.9
50	1 282.7	1 325.6	1 357.4	1 317.8	1 355.9	1 419.4	1 295.4	1 346.2	1 403.4	1 320.8	1 371.6	1 447.8	Note (4)	Note (4)	Note (4)
52	1 333.5	1 376.4	1 408.2	1 368.6	1 406.7	1 470.2	1 346.2	1 397.0	1 454.2	1 371.6	1 422.4	1 498.6	Note (4)	Note (4)	Note (4)
54	1 384.3	1 422.4	1 463.8	1 403.4	1 454.2	1 530.4	1 403.4	1 454.2	1 517.7	1 428.8	1 479.6	1 555.8	Note (4)	Note (4)	Note (4)
56	1 444.8	1 478.0	1 514.6	1 479.6	1 524.0	1 593.9	1 454.2	1 505.0	1 568.5	1 479.6	1 530.4	1 612.9	Note (4)	Note (4)	Note (4)
58	1 500.6	1 528.8	1 579.6	1 535.2	1 573.3	1 655.8	1 505.0	1 555.8	1 619.3	1 536.7	1 587.5	1 663.7	Note (4)	Note (4)	Note (4)
60	1 557.3	1 586.0	1 630.4	1 589.0	1 630.4	1 706.6	1 568.5	1 619.3	1 682.8	1 593.9	1 644.7	1 733.6	Note (4)	Note (4)	Note (4)
U.S. Customary Units, in.															
Flange Size (NPS)	Class 150			Class 300			Class 400			Class 600			Class 900		
	Grooved Core		Centering-Ring Outside Diameter, d3 [Note (3)]	Grooved Core		Centering-Ring Outside Diameter, d3 [Note (3)]	Grooved Core		Centering-Ring Outside Diameter, d3 [Note (3)]	Grooved Core		Centering-Ring Outside Diameter, d3 [Note (3)]	Grooved Core		Centering-Ring Outside Diameter, d3 [Note (3)]
	Inside Diameter, d1 [Note (1)]	Outside Diameter, d2 [Note (2)]		Inside Diameter, d1 [Note (1)]	Outside Diameter, d2 [Note (2)]		Inside Diameter, d1 [Note (1)]	Outside Diameter, d2 [Note (2)]		Inside Diameter, d1 [Note (1)]	Outside Diameter, d2 [Note (2)]		Inside Diameter, d1 [Note (1)]	Outside Diameter, d2 [Note (2)]	
	26	26.50	27.50	28.56	26.50	28.00	30.38	26.25	27.50	29.38	26.13	28.13	30.13	27.25	29.50
28	28.50	29.50	30.56	28.50	30.00	32.50	28.13	29.50	31.50	27.75	29.75	32.25	29.25	31.50	35.50
30	30.50	31.50	32.56	30.50	32.00	34.88	30.13	31.75	33.75	30.63	32.63	34.63	31.75	33.75	37.75
32	32.50	33.50	34.69	32.50	34.00	37.00	32.00	33.88	35.88	32.75	34.75	36.75	34.00	36.00	40.00
34	34.50	35.75	36.81	34.50	36.00	39.13	34.13	35.88	37.88	35.00	37.00	39.25	36.25	38.25	42.25
36	36.50	37.75	38.88	36.50	38.00	41.25	36.13	38.00	40.25	37.00	39.00	41.25	37.25	39.25	44.25

Table GM-2.1-3 Dimensions for Grooved Metal Gaskets With Covering Layers Used With ASME B16.47 Series B Flanges (Cont'd)

U.S. Customary Units, in.															
Flange Size (NPS)	Class 150			Class 300			Class 400			Class 600			Class 900		
	Grooved Core		Centering- Ring Outside Diameter, <i>d</i> 3 [Note (3)]	Grooved Core		Centering- Ring Outside Diameter, <i>d</i> 3 [Note (3)]	Grooved Core		Centering- Ring Outside Diameter, <i>d</i> 3 [Note (3)]	Grooved Core		Centering- Ring Outside Diameter, <i>d</i> 3 [Note (3)]	Grooved Core		Centering- Ring Outside Diameter, <i>d</i> 3 [Note (3)]
	Inside Diameter, <i>d</i> 1	Outside Diameter, <i>d</i> 2		Inside Diameter, <i>d</i> 1	Outside Diameter, <i>d</i> 2		Inside Diameter, <i>d</i> 1	Outside Diameter, <i>d</i> 2		Inside Diameter, <i>d</i> 1	Outside Diameter, <i>d</i> 2		Inside Diameter, <i>d</i> 1	Outside Diameter, <i>d</i> 2	
	[Note (1)]	[Note (2)]	[Note (1)]	[Note (2)]	[Note (1)]	[Note (2)]	[Note (1)]	[Note (2)]	[Note (1)]	[Note (2)]	[Note (1)]	[Note (2)]	[Note (1)]	[Note (2)]	
38	38.38	39.75	41.13	39.75	41.25	43.25	38.25	40.25	42.25	39.00	41.00	43.50	40.75	42.75	47.25
40	40.25	41.88	43.13	41.75	43.25	45.25	40.38	42.38	44.38	41.25	43.25	45.50	43.25	45.25	49.25
42	42.50	43.88	45.13	43.75	45.25	47.25	42.38	44.38	46.38	43.50	45.50	48.00	45.25	47.25	51.25
44	44.25	45.88	47.13	45.75	47.25	49.25	44.50	46.50	48.50	45.75	47.75	50.00	47.50	49.50	53.88
46	46.50	48.19	49.44	47.88	49.38	51.88	47.00	49.00	50.75	47.75	49.75	52.25	50.00	52.00	56.50
48	48.50	50.00	51.44	49.75	51.63	53.88	49.00	51.00	53.00	50.00	52.00	54.75	52.00	54.00	58.50
50	50.50	52.19	53.44	51.88	53.38	55.88	51.00	53.00	55.25	52.00	54.00	57.00	Note (4)	Note (4)	Note (4)
52	52.50	54.19	55.44	53.88	55.38	57.88	53.00	55.00	57.25	54.00	56.00	59.00	Note (4)	Note (4)	Note (4)
54	54.50	56.00	57.63	55.25	57.25	60.25	55.25	57.25	59.75	56.25	58.25	61.25	Note (4)	Note (4)	Note (4)
56	56.88	58.19	59.63	58.25	60.00	62.75	57.25	59.25	61.75	58.25	60.25	63.50	Note (4)	Note (4)	Note (4)
58	59.08	60.19	62.19	60.44	61.94	65.19	59.25	61.25	63.75	60.50	62.50	65.50	Note (4)	Note (4)	Note (4)
60	61.31	62.44	64.19	62.56	64.19	67.19	61.75	63.75	66.25	62.75	64.75	68.25	Note (4)	Note (4)	Note (4)

GENERAL NOTE: For reference, see [Figure GM-2.1-1](#).

NOTES:

- (1) The gasket inside diameter, *d*1, tolerance for NPS 26 through NPS 34 is ±0.8 mm (±0.03 in.), and the tolerance for NPS 36 through NPS 60 is ±1.5 mm (±0.06 in.).
- (2) The gasket outside diameter, *d*2, tolerance for NPS 26 through NPS 60 is ±1.5 mm (±0.06 in.).
- (3) The centering-ring outside diameter, *d*3, tolerance is ±0.8 mm (±0.03 in.).
- (4) There are no Class 900 flanges in NPS 50 and larger.

Table GM-3.1-1 Color Coding and Abbreviations for Grooved Metal Gaskets With Covering Layers Materials

Material	Abbreviation	Color Code
Grooved Metal Core Materials		
Carbon steel	CRS	Silver
Type 304 SS	304	Yellow
Type 304 L SS	304 L	No color
Type 309 SS	309	No color
Type 310 SS	310	No color
Type 316 L SS	316 L	Green
Type 317 L SS	317 L	Maroon
Type 321 SS	321	Turquoise
Type 347 SS	347	Blue
Type 430 SS	430	No color
Ni-Cu
Monel 400	MON	Orange
Grade 400
Nickel 200	NI	Red
Titanium	TI	Purple
20Cb-3 alloy	A-20	Black
Ni-Mo
Hastelloy B	HAST B	Brown
Grade B2
Grade B3
Ni-Mo-Cr
Hastelloy C	HAST C	Beige
Grade C-276
Ni-Cr-Fe
Inconel 600	INC 600	Gold
Grade 600
Ni-Cr-Fe-Cb
Inconel 625	INC 625	Gold
Grade 625
Ni-Cr-Fe-Ti
Inconel X-750	INX	No color
Grade X-750
Ni-Fe-Cr
Incoloy 800	IN 800	White
Grade 800
Ni-Fe-Cr-Mo-Cu
Incoloy 825	IN 825	White
Grade 825
Zirconium	ZIRC	No color
All Other Materials	Manufacturer's standard	No color
Nonmetallic Covering Materials		
Polytetrafluoroethylene	PTFE	White stripe
Flexible graphite	FG	Gray stripe
Vermiculite	...	Light blue stripe
Phlogopite (magnesium mica)	...	Light blue stripe

Table GM-4.1-1 Example Markings for Grooved Metal Gaskets With Covering Layers

Description	Marking
NPS 3, Classes 300 and 600 ASME B16.5 gaskets having a Type 304 core and a flexible graphite facing material	3-300/600—FG (Manufacturer's trademark) ASME B16.20
NPS 12, Class 1500 ASME B16.5 gasket having an Inconel core and PTFE facing material	12-1500 INC 600—PTFE (Manufacturer's trademark) ASME B16.20

Figure GM-4.1-1 Illustration of Example Markings for Grooved Metal Gaskets With Covering Layers

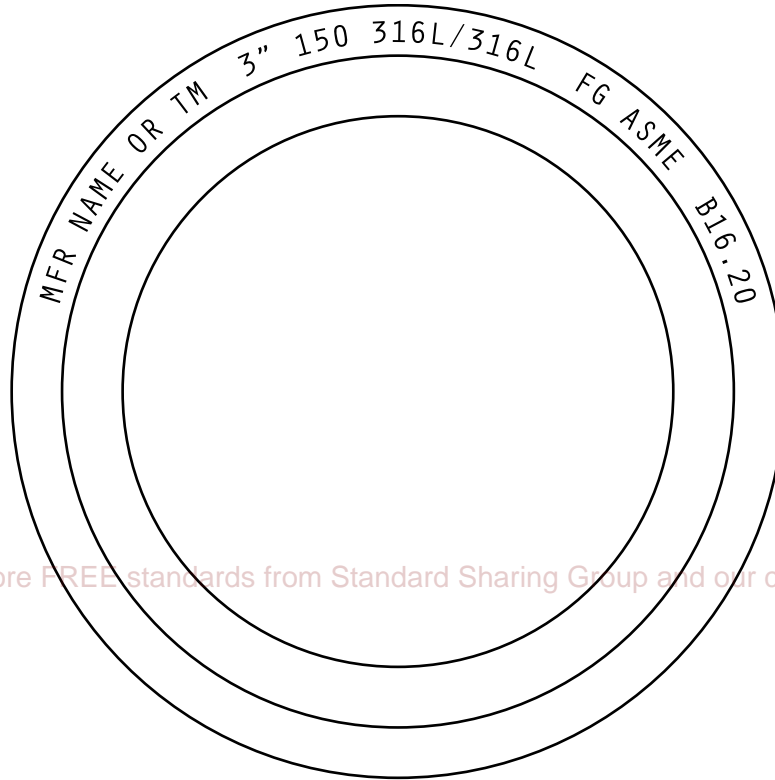

Get more FREE standards from Standard Sharing Group and our chats

GENERAL NOTE: Minimum letter height = 2.5 mm (0.1 in.).

MANDATORY APPENDIX I REFERENCES

The following is a list of publications referenced in this Standard. Unless otherwise specified, the latest issue shall apply.

API Specification 6A-2010, Specification for Wellhead and Christmas Tree Equipment

Publisher: American Petroleum Institute (API), 1220 L Street, NW, Washington, DC 20005 (www.api.org)

ASME B16.5, Pipe Flanges and Flanged Fittings: NPS $1/2$ Through NPS 24 Metric/Inch Standard

ASME B16.47, Large Diameter Steel Flanges: NPS 26 Through NPS 60 Metric/Inch Standard

ASME B36.10M, Welded and Seamless Wrought Steel Pipe

ASME B36.19M, Stainless Steel Pipe

Publisher: The American Society of Mechanical Engineers (ASME), Two Park Avenue, New York, NY 10016-5990 (www.asme.org)

ISO 9001:2005, Quality management systems — Requirements

ISO 10423:2009, Petroleum and natural gas industries — Drilling and production equipment — Wellhead and Christmas tree equipment

Publisher: International Organization for Standardization (ISO), Central Secretariat, Chemin de Blandonnet 8, Case postale 401, 1214 Vernier, Geneva, Switzerland (www.iso.org)

NONMANDATORY APPENDIX A QUALITY SYSTEM PROGRAM

The products manufactured in accordance with this Standard shall be produced under a quality system program following the principles of an appropriate standard from the ISO 9000 series.¹ A determination of the need for registration and/or certification of the product manufacturer's quality system program by an independent organization shall be the responsibility of the manufacturer. The detailed documentation demon-

strating program compliance shall be available to the purchaser at the manufacturer's facility. A written summary description of the program utilized by the product manufacturer shall be available to the purchaser upon request. The product manufacturer is defined as the entity whose name or trademark appears on the product in accordance with the marking or identification requirements of this Standard.

Get more FREE standards from Standard Sharing Group and our chats

¹ The series is also available from the American National Standards Institute (ANSI) and the American Society for Quality (ASQ) as American National Standards that are identified by the prefix "Q," replacing the prefix "ISO." Each standard of the series is listed under References in [Mandatory Appendix I](#).

INTENTIONALLY LEFT BLANK

B16 AMERICAN NATIONAL STANDARDS FOR PIPING, PIPE FLANGES, FITTINGS, AND VALVES

B16.1-2015	Gray Iron Pipe Flanges and Flanged Fittings (Classes 25, 125, and 250)
B16.3-2016	Malleable Iron Threaded Fittings: Classes 150 and 300
B16.4-2016	Gray Iron Threaded Fittings: Classes 125 and 250
B16.5-2017	Pipe Flanges and Flanged Fittings NPS ½ Through NPS 24 Metric/Inch Standard
B16.9-2012	Factory-Made Wrought Butt welding Fittings
B16.10-2017	Face-to-Face and End-to-End Dimensions of Valves
B16.11-2016	Forged Fittings, Socket-Welding and Threaded
B16.12-2009 (R2014)	Cast Iron Threaded Drainage Fittings
B16.14-2013	Ferrous Pipe Plugs, Bushings, and Locknuts With Pipe Threads
B16.15-2013	Cast Copper Alloy Threaded Fittings
B16.18-2012	Cast Copper Alloy Solder Joint Pressure Fittings
B16.20-2017	Metallic Gaskets for Pipe Flanges
B16.21-2016	Nonmetallic Flat Gaskets for Pipe Flanges
B16.22-2013	Wrought Copper and Copper Alloy Solder-Joint Pressure Fittings
B16.23-2016	Cast Copper Alloy Solder Joint Drainage Fittings: DWV
B16.24-2016	Cast Copper Alloy Pipe Flanges, Flanged Fittings, and Valves: Classes 150, 300, 600, 900, 1500, and 2500
B16.25-2017	Butt welding Ends
B16.26-2013	Cast Copper Alloy Fittings for Flared Copper Tubes
B16.29-2017	Wrought Copper and Wrought Copper Alloy Solder-Joint Drainage Fittings — DWV
B16.33-2012 (R2017)	Manually Operated Metallic Gas Valves for Use in Gas Piping Systems Up to 175 psi (Sizes NPS ½ Through NPS 2)
B16.34-2017	Valves — Flanged, Threaded, and Welding End
B16.36-2015	Orifice Flanges
B16.38-2012 (R2017)	Large Metallic Valves for Gas Distribution: Manually Operated, NPS 2½ (DN 65) to NPS 12 (DN 300), 125 psig (8.6 bar) Maximum
B16.39-2014	Malleable Iron Threaded Pipe Unions: Classes 150, 250, and 300
B16.40-2013	Manually Operated Thermoplastic Gas Shutoffs and Valves in Gas Distribution Systems
B16.42-2016	Ductile Iron Pipe Flanges and Flanged Fittings: Classes 150 and 300
B16.44-2012 (R2017)	Manually Operated Metallic Gas Valves for Use in Aboveground Piping Systems Up to 5 psi
B16.47-2017	Large Diameter Steel Flanges NPS 26 Through NPS 60 Metric/Inch Standard
B16.48-2015	Line Blanks
B16.49-2017	Factory-Made, Wrought Steel, Butt welding Induction Bends for Transportation and Distribution Systems
B16.50-2013	Wrought Copper and Copper Alloy Braze-Joint Pressure Fittings
B16.51-2013	Copper and Copper Alloy Press-Connect Pressure Fittings

The ASME Publications Catalog shows a complete list of all the Standards published by the Society. For a complimentary catalog, or the latest information about our publications, call 1-800-THE-ASME (1-800-843-2763).

ASME Services

ASME is committed to developing and delivering technical information. At ASME's Customer Care, we make every effort to answer your questions and expedite your orders. Our representatives are ready to assist you in the following areas:

ASME Press	Member Services & Benefits	Public Information
<i>Codes & Standards</i>	Other ASME Programs	Self-Study Courses
Credit Card Orders	Payment Inquiries	Shipping Information
IMEchE Publications	Professional Development	Subscriptions/Journals/Magazines
Meetings & Conferences	Short Courses	Symposia Volumes
Member Dues Status	Publications	Technical Papers

How can you reach us? It's easier than ever!

There are four options for making inquiries* or placing orders. Simply mail, phone, fax, or E-mail us and a Customer Care representative will handle your request.

<i>Mail</i>	<i>Call Toll Free</i>	<i>Fax—24 hours</i>	<i>E-Mail—24 hours</i>
ASME	US & Canada: 800-THE-ASME	973-882-1717	customercare@asme.org
150 Clove Road, 6th Floor	(800-843-2763)	973-882-5155	
Little Falls, New Jersey	Mexico: 95-800-THE-ASME		
07424-2139	(95-800-843-2763)		

*Customer Care staff are not permitted to answer inquiries about the technical content of this code or standard. Information as to whether or not technical inquiries are issued to this code or standard is shown on the copyright page. All technical inquiries must be submitted in writing to the staff secretary. Additional procedures for inquiries may be listed within.

ASME B16.20-2017

Get more FREE standards from Standard Sharing Group and our chats

ISBN 978-0-7918-7192-8

